

MERTON UNITARY
DEVELOPMENT PLAN



SPG

SUPPLEMENTARY PLANNING GUIDANCE NOTE

Residential Extensions, Alterations & Conversions

NOVEMBER 2001

MERTON UNITARY DEVELOPMENT PLAN SUPPLEMENTARY PLANNING GUIDANCE NOTE



Residential Extensions, Alterations & Conversions

NOVEMBER 2001

MERTON UNITARY DEVELOPMENT PLAN SUPPLEMENTARY PLANNING GUIDANCE NOTE

Explanatory Note

The Unitary Development Plan (UDP), adopted in April 1996 is undergoing a process of review. A revised version of the UDP has been considered at a Public Inquiry held in 2001.

This Supplementary Planning Guidance Note (SPG) has been prepared as part of the Revised Plan. The SPG does not form part of the UDP but will be taken into account by the Council in determining Planning Applications.

Please note that, except where indicated otherwise, all reference to UDP policies in this document relate to the revised UDP (October 2000), together with revised policies, where relevant, emerging from the Inquiry.

NOVEMBER 2001



Supplementary Planning Guidance

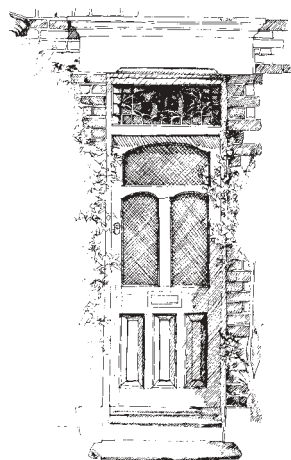

Residential Extensions, Alterations & Conversions

NOVEMBER 2001

www.merton.gov.uk

Contents

1.0	INTRODUCTION	4
2.0	PLANNING POLICIES & GUIDANCE	6
3.0	EXTENDING A RESIDENTIAL PROPERTY	7
3.1	Side Extensions	7
3.2	Rear Extensions	9
3.3	Porches and Front Extensions	12
3.4	Roof Extensions	14
3.5	Privacy	17
3.6	Trees	18
4.0	DETAILED DESIGN CONSIDERATIONS	19
4.1	Roof Design	19
4.2	Materials	20
4.3	Windows	21
4.4	Doors, Porches & Front Garden Paths	22
4.5	Decorative Details	22
5.0	RESIDENTIAL CONVERSIONS	23
5.1	Is the Property suitable for Conversion?	23
5.2	Layout of Conversion Schemes	23
5.3	Space Standards	25
5.4	Amenity Space & Bin Stores	25
5.5	Car Parking	26
5.6	Sound Insulation	28
5.7	Party Walls	30
6.0	CONTACTS	30
6.1	APPENDIX	31

NB. This document seeks to combine Supplementary Planning Guidance, which will be taken into account in the determination of planning applications, and more general advice and good practice, aimed purely at informing readers.

The distinctions of typeface will be used to distinguish the one from the other. In this document, the general advice and good practice, is shown **thus**, to distinguish it from SPG content.

1.0 Introduction

.....

1.0.1 This is one of a series of Supplementary Planning Guidance Notes available on a diverse range of subjects, which should be read in conjunction with the Council's Adopted Unitary Development Plan (UDP). It is proposed that these notes will be updated as and when necessary to reflect any changes that may occur in Government guidance and advice. This SPG Note was placed on deposit during the first deposit stage of the UDP preparation in September 1999, and has been amended in the light of representations made during that deposit period.

1.0.2 This Supplementary Planning Guidance Note identifies the Council's requirements in relation to residential alterations, extensions and conversions. The guidance is not a set of hard and fast rules, but suggests ways in which commonly recurring problems can be resolved.

1.0.3 The guidance set out in this document will be considered when assessing planning applications for new development of this type. Developers are therefore advised to take note, and apply its contents where appropriate. However, the solutions offered are not exhaustive, and the designers own imagination may in some cases identify alternative ways of proceeding, which may meet the intentions of this document. Nevertheless the development will certainly have to comply with the Council's Planning Policies which are contained in the Unitary Development Plan.

1.0.4 References to additional information on the subject matter are contained within the text of the guidance note and are indicated by the book symbol as shown here. 

1.0.5 This Note provides guidance to help you obtain planning permission when extending or altering a residential property. In this way it will help ensure that the nature of the proposal is complementary to, and enhances, both the existing property and those in the surrounding area. Careful thought given at an early stage will help to achieve a

good design that makes the best possible use of the existing situation.

1.0.6 Sometimes planning permission from the Council will not be required, as it may be the case that the proposal is what is known as "permitted development". Definitions of what is "permitted development" are detailed in the Town and Country Planning (General Permitted Development) Order 1995. The legislation is quite complicated, but it basically outlines what development can be carried out without the need for planning permission. This depends on the extent or siting of the proposed alterations, where the property is located and whether other alterations have previously been carried out. The General Permitted Development Order is periodically updated by Central Government, and for this reason you are advised to contact the Development Control Section of the Environmental Services Department for information on the need to apply for planning permission, and how to apply for it (see the Contacts List at the end of this note).



(further guidance - Town and Country Planning (General Permitted Development) Order 1995, and "Planning - A Guide for Householders", DoE March 1966. Copies available from the Development Control Section of the Environmental Services Dept. see Contacts List.)

1.0.7 This Guidance Note deals mainly with aspects relating to planning permission. However, it should always be remembered that when you are extending, altering or converting a property, **then there are other permissions that may be required, such as Building Regulations Approval, works to trees, permissions for crossovers and dropped kerbs, and Listed Building Consent.** It is up to the person submitting the application to ensure that all the relevant permissions have been obtained. It is therefore always necessary to contact the Council to check what consents are required. (See Contacts section of this Note for information to find out if a building is Listed or if trees are protected).

1.0.8 Although you may obtain one type of permission, it does not necessarily mean that the others are included, or indeed imply that they will all be granted. A large number of works will require Building Regulations Approval but not necessarily Planning Permission, whilst others will require both.

1.0.9 The extension, conversion, or alteration of a Listed Building will require additional Listed Building Consent in addition to planning permission. An extremely high quality scheme will be required in such instances and applicants are therefore strongly advised to contact the Environmental Services Department when first considering such a proposal (see Contacts List for contact for works to Listed Buildings).

1.0.10 Buildings in Conservation Areas also require additional consideration, including detailed design matters in relation to alterations and extensions, and the protection of trees.

1.0.11 The trees within a site may be protected by a Tree Preservation Order, whilst in Conservation Areas the Council are likely to require prior notification of any planned works to trees. In order to find out if either of these situations applies to a specific site, or a specific tree you should contact the Council's Tree Officer (see Contacts List).

1.0.12 Building Regulations ensure the sound construction of buildings, making them safe to use. This is different from planning control, which is concerned more with the use or appearance of land and buildings. If you require advice on Building Regulations then please contact the Building Control Section of the Environmental Services Department (see Contacts List).



(Further guidance - "Building Regulations, Explanatory Booklet", DETR July 1998. Copies available from the Building Control Section of the Environmental Services Dept. see Contacts List).

1.0.13 Extensions and alterations to residential properties cannot be carried out in a mechanistic

manner, as dwellings in the borough differ in many ways. However, this Guidance Note gives some positive advice when carrying out such changes, and will be referred to by the Council when determining planning applications. In this way the quality of our residential environment can be protected for future generations.

1.0.14 For simplicity's sake, this note is divided into a number of different subjects. However, you should not just read one part of the note relevant to your proposal, as there are many overlapping issues, in particular any changes envisaged for a residential property need to have regard to the detailed design considerations set out in section 4 of this Note. This note should therefore be read as a whole, and its contents should wherever possible be applied as an integral part of the final proposal.

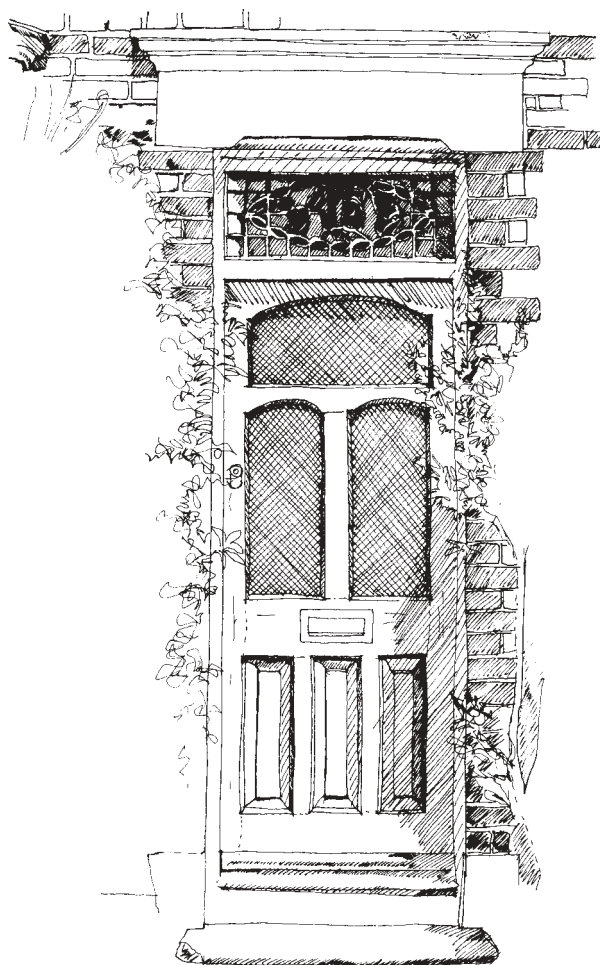

2.0 Planning Policies and Guidance

2.0.1 Merton's Unitary Development Plan contains the Council's planning policies on what it considers should and should not be given planning permission. These policies should therefore be complied with when formulating any proposal. The policies relating to residential extensions and alterations are principally contained within the Environment Chapter of the plan, although there are other equally important policies in the Housing Chapter and elsewhere that apply. Policies relating to conversions are to be found in the Housing Chapter. The policies have been formulated on the basis of Government Guidance and legislation. The most relevant policies are:

- ST.1a Sustainable Development
- ST.12 Housing Provision
- BE.21 New Buildings and Extensions, Daylight and Sunlight
- BE.22 New Buildings and Extensions, Loss of Privacy and Visual Intrusion
- BE.24 Gardens and Incidental Open Spaces
- BE.28 Design of New Development
- BE.29 Alterations and Extensions to Buildings
- BE.30 Roof Extensions and Dormer Windows
- BE.31 Sustainable Development
- BE.41 Re Use of Buildings
- MU.2 Mixed Use Frontages, Upper Floor Uses
- HP.3 Retention of Residential Accommodation
- HP.5 Rehabilitation and Vacant Dwellings
- HP.8 Flat Conversions, Size of Original Unit
- HP.8b Flat Conversion, Retention of Units
- HP.9 Houses in Multiple Occupation
- HN.7 Residential Institutional Uses
- HN.8 Accommodation for Homeless People
- HS.1 Housing Layout and Amenity
- HS.2 Amenity Space and Gardens
- HS.3 Flat Conversions, Standard of Accommodation
- HS.4 Sustainable Housing

 (further guidance - Draft Unitary Development Plan, London Borough of Merton, 2000. See Contacts List).

2.0.2 The Council also prepares further guidance and advice on a regular basis in the form of design guides. These generally relate to Conservation Areas within the borough, where stricter statutory controls will be applied to residential extensions and alterations. A guide has been prepared for several conservation areas giving information, on history and design advice, and explaining in detail how alterations to buildings should be carried out to reflect the special architectural or historic character of each particular area.

 (Further guidance - Conservation and Special Areas Design Guides see Contacts List)

2.0.3 In addition to the Design Guides, the Council has prepared Supplementary Planning Guidance Notes and other design leaflets on a variety of other subjects, some of which may be relevant to proposals for altering, converting or extending residential properties.

 (Further guidance - Supplementary Planning Guidance on traffic and parking, planting landscaping and nature conservation, designing out crime, accessible environments, affordable housing, and sustainable development, and Design Guidance leaflet on Front Garden Parking (See Contacts list).



3.0 Extending a Residential Property

3.0.1 As well as considering the effect of the proposal on the appearance or character of the original building and the street as a whole, it is also important to consider how the extension will affect its neighbours. Whilst an extension may successfully reflect the design characteristics of the surrounding buildings, it can also affect the amenities enjoyed by neighbouring properties, such as the privacy they enjoy, the daylight, sunlight or outlook from their windows or garden areas and the sense of spaciousness between neighbours.

3.0.2 The Council will consider all of these issues when determining a planning application, and they should therefore be taken into account at an early stage by the applicant.

3.1 SIDE EXTENSIONS

3.1.1 The design of any side extension to a property should always be in sympathy with the design of the original building. This can be achieved either by

integrating the extension into the original, so that it looks as though it has not been extended, or by subordinating the extension by using a lower roof and setting it back behind the principal facade. However in some cases side extensions of any kind will not be acceptable.

3.1.2 An integrated approach can work well with a detached house or with an end of terrace dwelling. Sometimes however it can destroy the symmetry of a dwelling or a building, or disrupt the rhythm of buildings and spaces between buildings in a street, especially where the buildings in the street follow a standard form or are evenly and regularly spaced.

3.1.3 A subordinated form of extension is likely to be more appropriate in circumstances where it is desirable that the proportions or symmetry of the original building should be appreciated. Windows, doors and other features should generally be at a reduced scale in subordinated extensions.

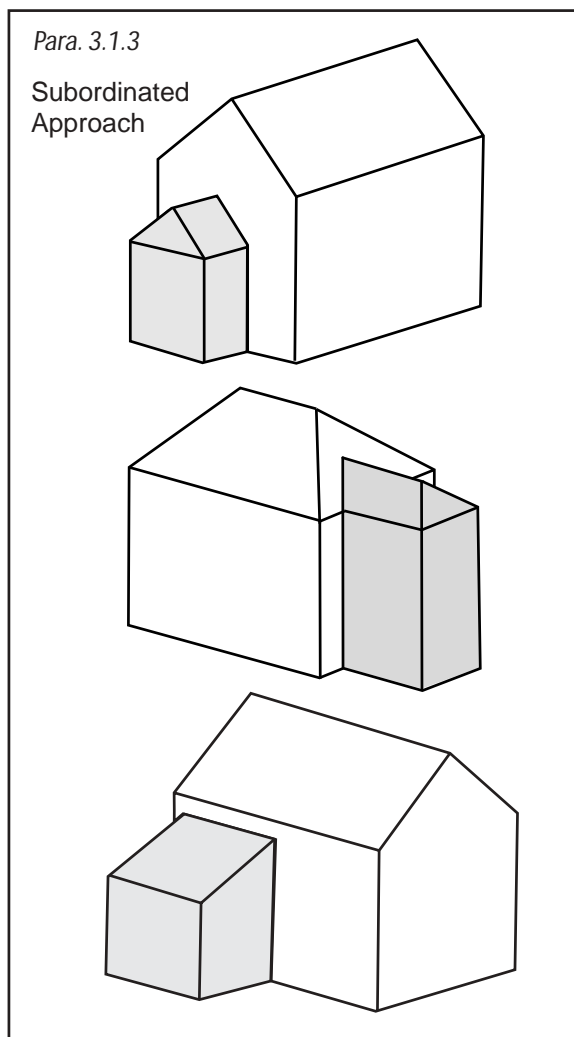
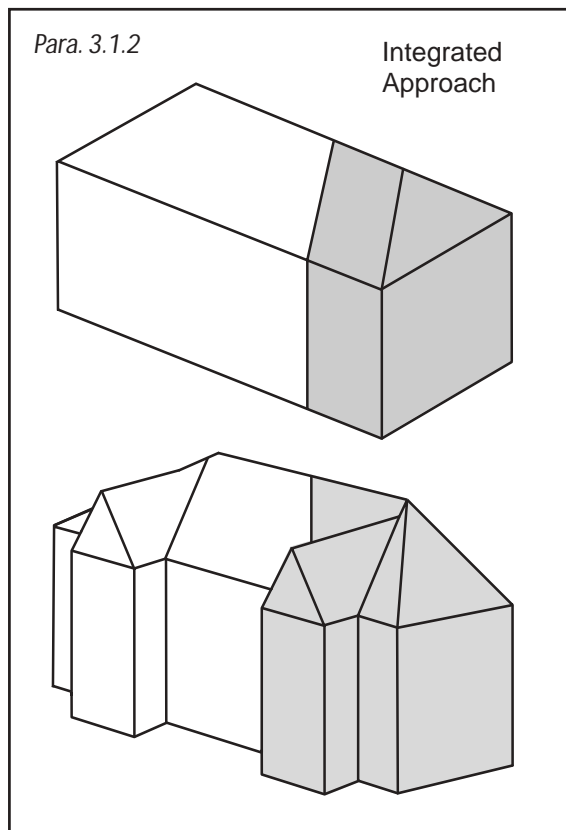

Para. 3.1.4

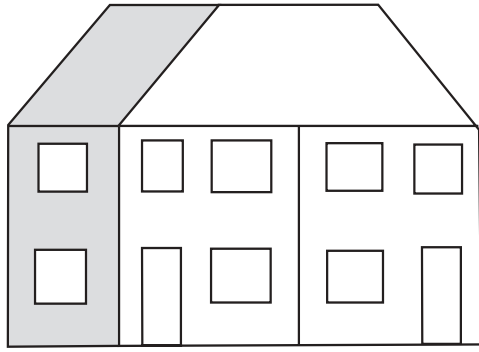

The symmetry on the building is lost

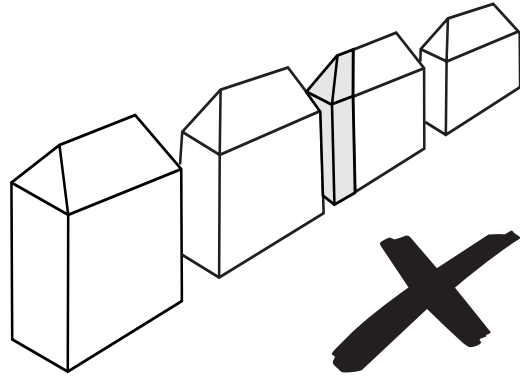

3.1.4 Where the regular rhythm of buildings, and spaces between buildings, are a feature of the street, or where the symmetry of the building would be affected, then side extensions of more than a single storey will not be permitted.

3.1.5 Where the buildings in a street comprise terraces of houses, with small spaces between each terrace, then side extensions for end of terrace houses of more than a single storey will not be permitted unless a separation of at least 1 metre is retained between the flank wall of the extension and the property boundary. This limit is imposed in order to avoid potential damage to the street scene arising out of terraces of excessive length, or street frontages with only token separations between terraces.

3.1.6 Where a hipped roof form is typical of the building, or typical of other buildings in the street, then a hipped roof should be used for the side extension. In such a case a gap of at least 1 metre should be retained between the flank wall of the side extension, and the property boundary. This limitation is imposed in order to avoid the future possibility of two hipped roofs touching, or nearly touching, at the eaves. However this will not be required where the adjacent land could not be built on.

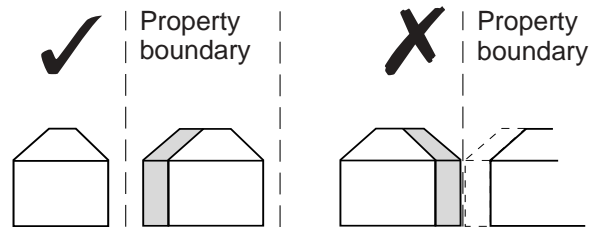

Para. 3.1.6

Para. 3.1.5

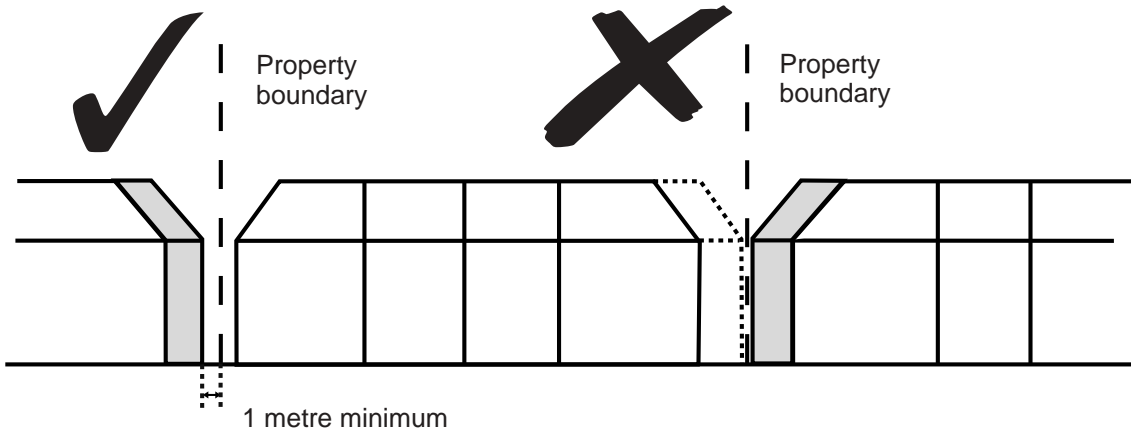

Para. 3.1.7

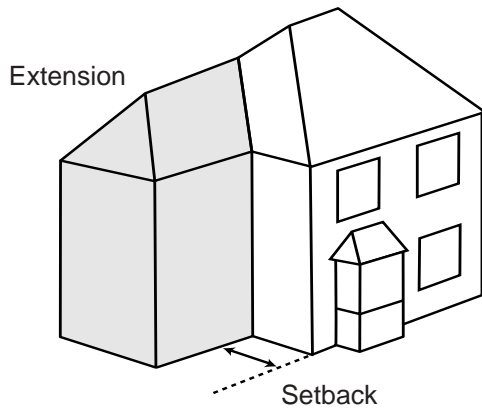

3.1.7 The front wall of any subordinate side extension should be set back by no less than 1 metre (and preferably by 1.5 metres) behind the main facade of the original building. This is required in order to achieve a satisfactory degree of subordination.

Para. 3.1.8

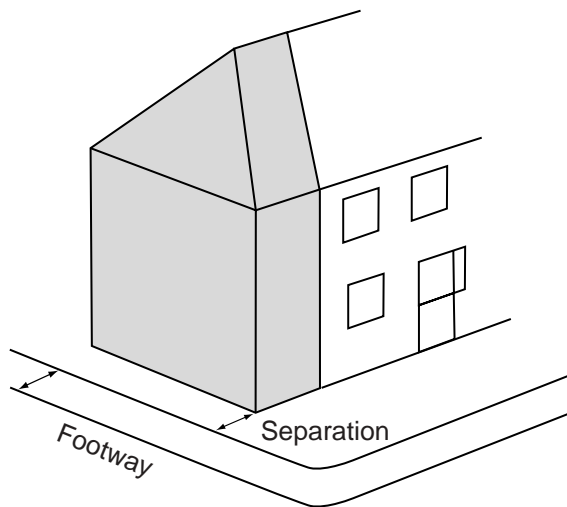

3.1.8 At street junctions, proposals for side extensions of more than a single storey may not be acceptable at all. Where it is possible then the flank wall of the extension would need to be set at least 1 metre from the back edge of the footway. This is required in order to retain a sense of spaciousness at street junctions.

3.1.9 Applicants will be asked to provide drawings to illustrate any proposal for a side extension showing the relationship to its neighbours.

3.2 REAR EXTENSIONS

3.2.1 Rear extensions are in many situations the most practical way of enlarging a dwelling. However, issues relating to privacy and the daylight and sunlight enjoyed by neighbouring properties are very important and must be taken into account. This is particularly the case if the property is part of a terrace or is a semi-detached property. This will ultimately restrict the final size and design of the extension.

Para. 3.2.2

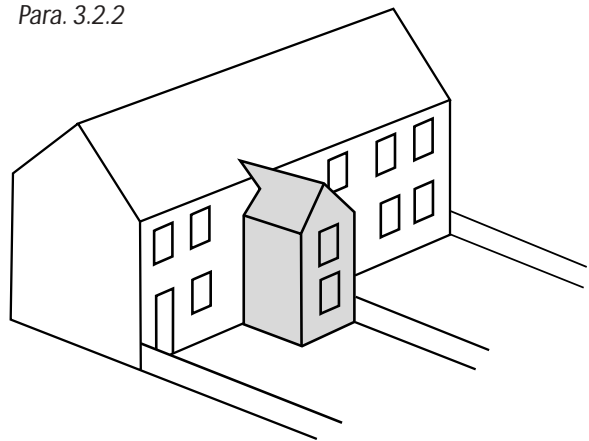

3.2.2 It is desirable to keep the eaves level and ridge line of the extension at a lower level than the eaves and ridge of the original dwelling.

3.2.3 Rear extensions will reduce the area of private amenity land available to the dwelling. Residential amenity space should not be reduced to less than 50 sq. metres for each house, or to less than 10 sq. metres per habitable room for flats. Where back garden land is already of minimal size, a rear extension may be ruled out altogether.

Para. 3.2.3

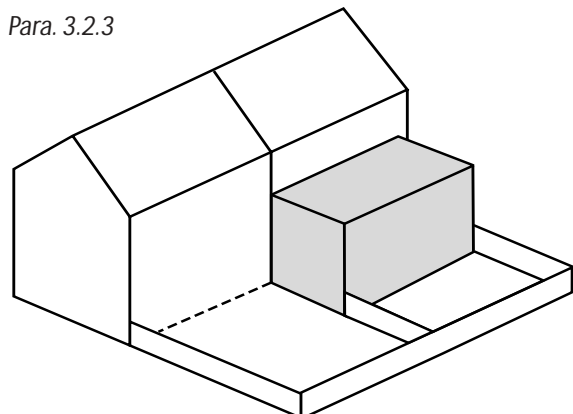

3.2.4 Rear extensions should seek to avoid the loss of sunlight and daylight to adjoining houses as well as to the building being extended. They should also avoid an unduly dominating effect on the neighbouring property. These considerations often restrict the potential for rear extensions, especially where an upper floor is involved.

3.2.5 Where properties are attached to a neighbouring dwelling, or are in close proximity to a neighbouring dwelling then the Council will carefully consider the effect of the extension on those neighbouring properties. When submitting a planning application in such instances, the location of the neighbouring properties should be clearly shown on both plans and elevational drawings, showing the position and size of the neighbouring properties nearest windows in relation to the proposed extension.

3.2.6 The following procedure will be applied to in terms of visual intrusion and loss of daylight and sunlight to neighbouring properties.

3.2.7 **STEP I.** Identify the position of the extension in relation to the windows of neighbouring properties, based on the "cartwheel" drawings (shown on the opposite page).

3.2.8 This will give an indication as to the effect of an extension on neighbouring properties in terms of the number of hours of sunlight that are likely to be lost once the extension has been built. It takes into account the importance of building orientations - for example, a room facing north may receive very little sunlight before an extension is built, and although the extension may result in only the loss of a few hours of sunlight to the neighbouring property, it may nevertheless mean that all those few hours of sun would be lost.

3.2.9 An "aspect value" of between 0 and 6 will be obtained, where 0 represents a situation where there will be least loss of daylight and sunlight and 6 where the most amount of daylight and sunlight will be lost.

Para 3.2.7 - Determining Aspect Values

Use these drawings to determine the relevant aspect value of the proposed extension in relation to the location of the neighbouring property's nearest window.

1. First find the orientation of the existing building - this will give you two choices, one in each of the "cartwheels".
2. One of these choices will show the location of the proposed extension in relation to the nearest neighbours's windows.
3. This is the relevant aspect value that should be used.

Para 3.2.7 - Key to diagram

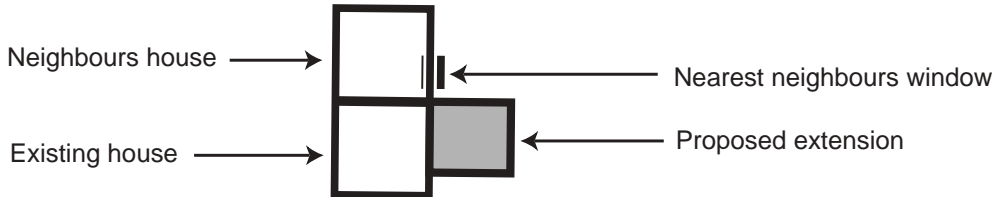

Para. 3.2.7
Upper Cartwheel

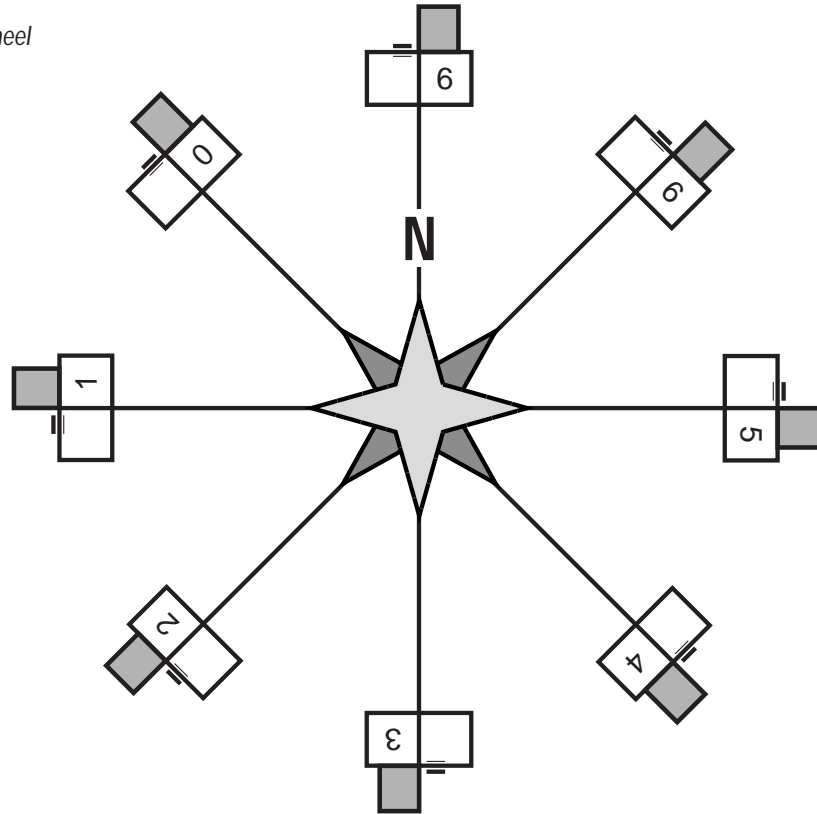

Para. 3.2.7
Lower Cartwheel

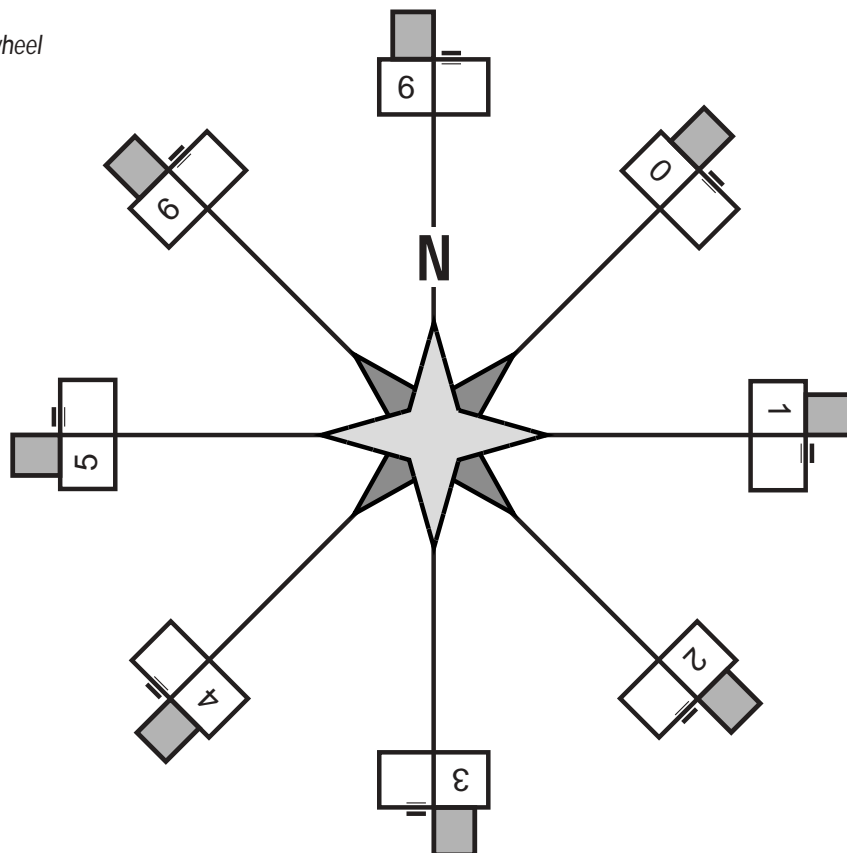

3.2.10 In the case of terraced properties, an extension may traverse the entire width of the rear of the property and therefore the extension would affect the daylight and sunlight of both neighbouring properties. However, due to the orientation of the building, one neighbour is likely to be affected more than the other. Therefore in such instances the worst case scenario should be taken, that is the neighbour which lies to the north of the proposed extension.

3.2.11 STEP 2. Ascertain the angle on plan between the centre point of the adjoining neighbour's window and the rear of the proposed extension. In the case of adjoining bay windows, the angle should be measured as if it were a normal window, and not from the protruding bay.

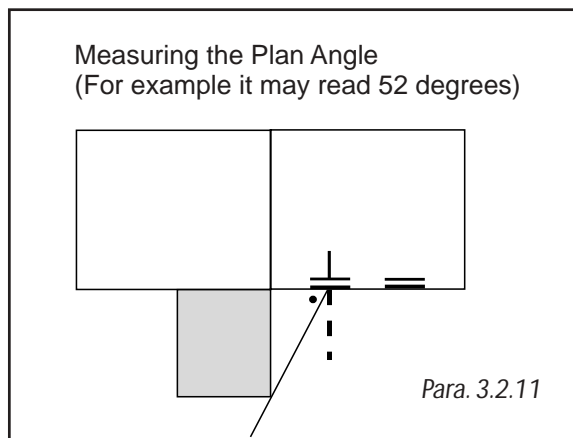

3.2.12 STEP 3. Measure the vertical angle on the proposed elevation from the centre point of the window, at a height of 1.7 metres (the optimum height for the centre of most windows), to the skyline of the extension.

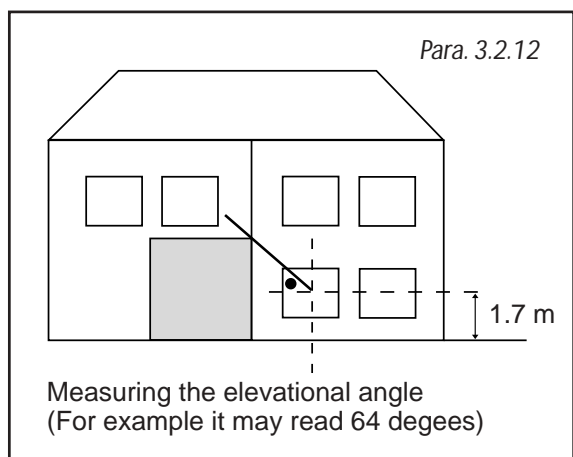

3.2.13 STEP 4. Plot the two angles on the graph (on page 13 opposite) and relate them to the aspect value found in Step 1. Each of the angles defines a line on the graph, if the point where the two lines intersect falls below the relevant aspect value line then the extension would in most instances be acceptable. If it falls above the relevant aspect value line, then the extension is too large and will not normally be acceptable.

3.3 PORCHES AND FRONT EXTENSIONS

3.3.1 Front extensions will not normally be permitted, except for porches and the addition of bay windows. This is because front extensions can have an intrusive effect on the street scene. In exceptional circumstances, if a dwelling is detached and standing in large grounds, then a front extension may be possible. However, as it could still have a significant impact on the street scene, a closely related architectural style to the original dwelling will be required, with careful detailing, matching materials and proportions.

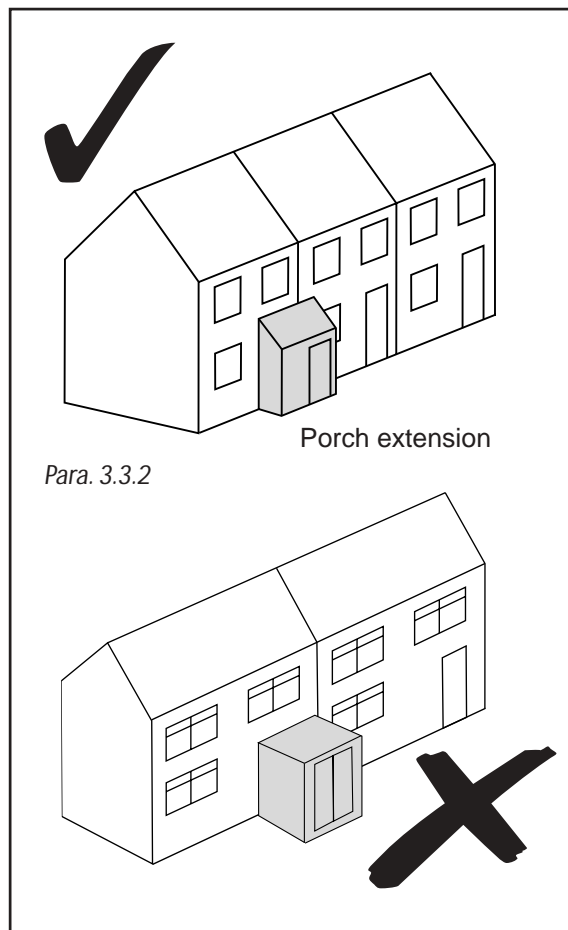

"Relating Plan and Elevational Angles to the Aspect Value"

Once the plan angle and elevational angle have been plotted, the result should fall BELOW the relevant aspect value if the extension is to comply with this guidance. If it falls above the relevant aspect value then the extension in most cases is not satisfactory.

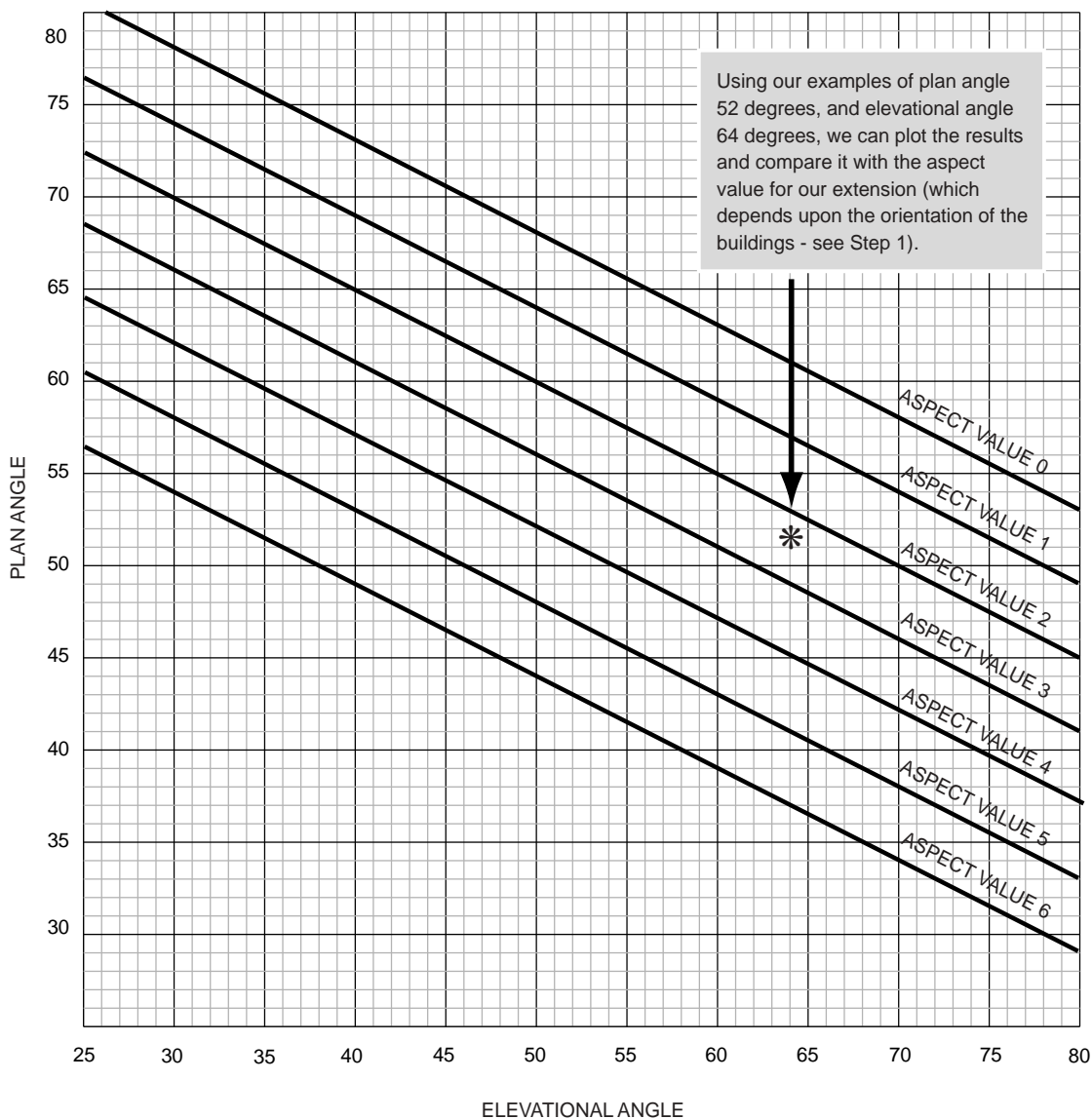

Para. 3.2.13

3.3.2 Porches and bay windows should not be of a size or scale that dominates the overall appearance of the dwelling and they too should be designed to harmonise with the architectural style of the building.

3.3.3 The addition of a front porch or the enclosure of an existing open fronted porch can conceal or destroy the fine detailing that is often associated with a front door and its surround, and this should therefore be avoided wherever possible.

3.4 ROOF EXTENSIONS

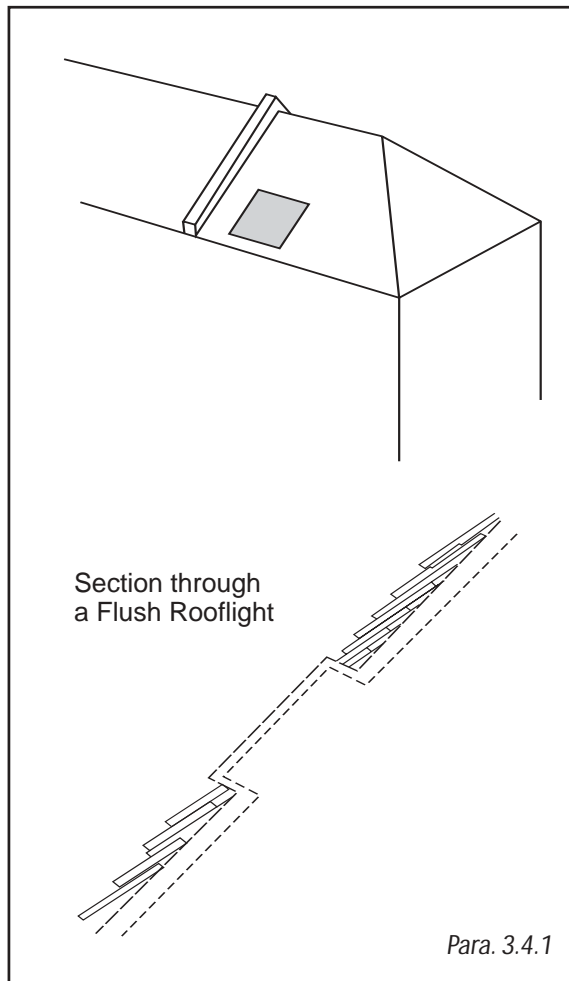

3.4.1 The use of loft space to provide living space or bedrooms can often provide additional space for relatively little cost. It is best, if possible to avoid any enlargement of the roof volume at all, and requirements for natural light can be provided by means of roof lights, which are parallel with the roof slope. Dormer windows, which project out from the roof slope should only be used where there is a need to enlarge useable floor space as well as providing natural light and an attractive outlook for the user.

3.4.2 Rooflights, which lie parallel with the plane of the roof (such as Velux windows), are the most sympathetic way of providing light to a habitable room within the roofspace. In Conservation Areas special flush rooflight windows will be required in situations where they may be seen from a public place.

3.4.3 The design of dormer windows has to be carefully considered, as they can appear obtrusive, and can have a damaging effect on the appearance of the dwelling as well as on the street scene.

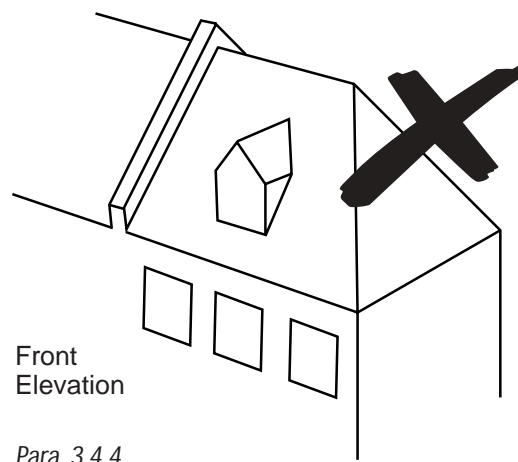

3.4.4. Except in special circumstances dormer windows are not acceptable on front elevations of buildings. Exceptional circumstances only apply if dormer windows are entirely consistent with the original architecture and detailing of the building, and if they echo the style of any original dormer windows on other similar buildings elsewhere in the immediate vicinity.

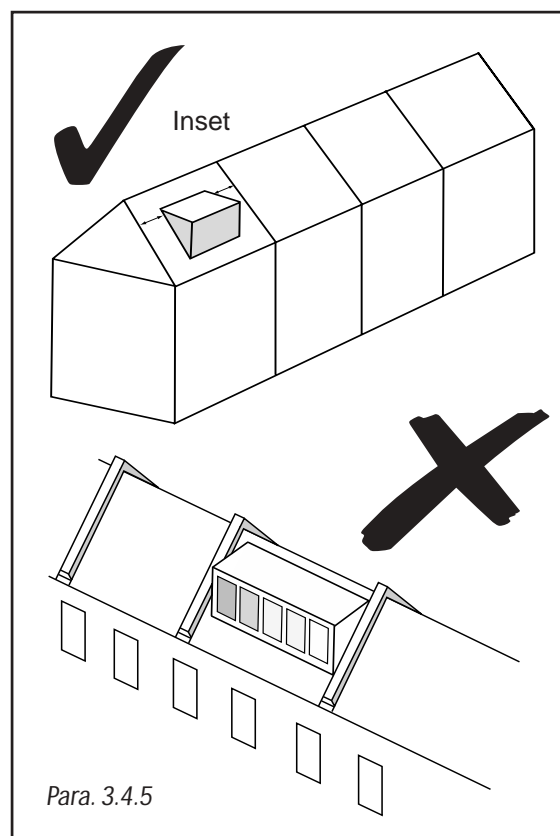

3.4.5 Roof extensions should not be overlarge. A dormer which runs the full width between the flank or party walls, or comes to within 1 metre of a party or flank wall is almost always unacceptable. An exception may however be considered when the roof extension is particularly small in relation to the roof plane in which it would be situated. *NB.* This limitation can have implications for the positioning of the stair access to the roofspace, and as a result for the room layout on the floor below. It is possible that in some instances this may preclude any practical extension of living space into the loft.

Para. 3.4.6

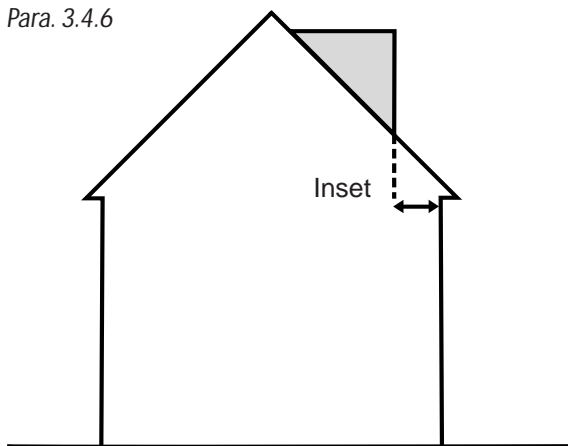

3.4.6 The window face of a roof extension should normally be set back by at least 1 (horizontal distance) behind the main facade of the building. An exception to this can however be made in situations where there are examples on the building or on similar buildings in the vicinity of original dormer windows which do not have this set back.

Para. 3.4.7

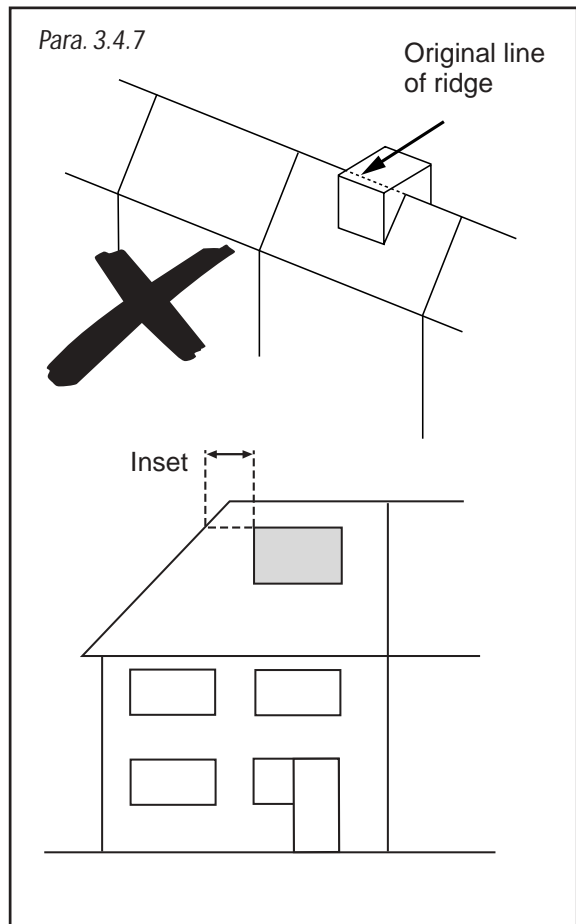

3.4.7 Roof extensions should not break the line of ridge or hip tiles on the roof, nor should they come to within 0.5 metre (measured horizontally) of the hip tiles.

3.4.8 The following examples are preferred designs for dormer windows, and they may be required in Conservation Areas and elsewhere, depending on the particular character of that area or the specific building.

Para. 3.4.8

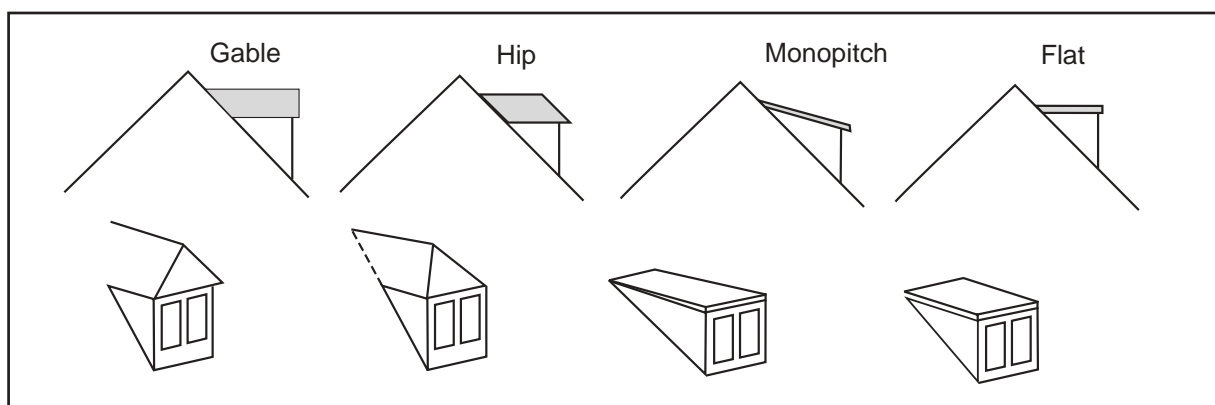

3.4.9 The design of the dormer should firstly be appropriate to the character of the building to be extended, and secondly to the character of the neighbouring buildings. This should take account of the width and height of the dormer, the materials to be used, detailing, and the roof pattern of the dormer. The use of a pitched roof, (either hipped or gabled), over the dormer windows often looks better than a flat roof. Well detailed dormer windows of this kind will be required in conservation areas and may be sought elsewhere.

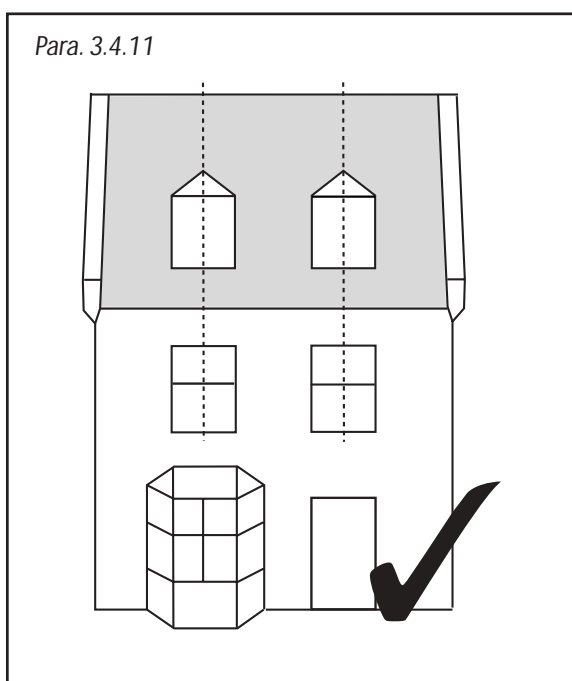
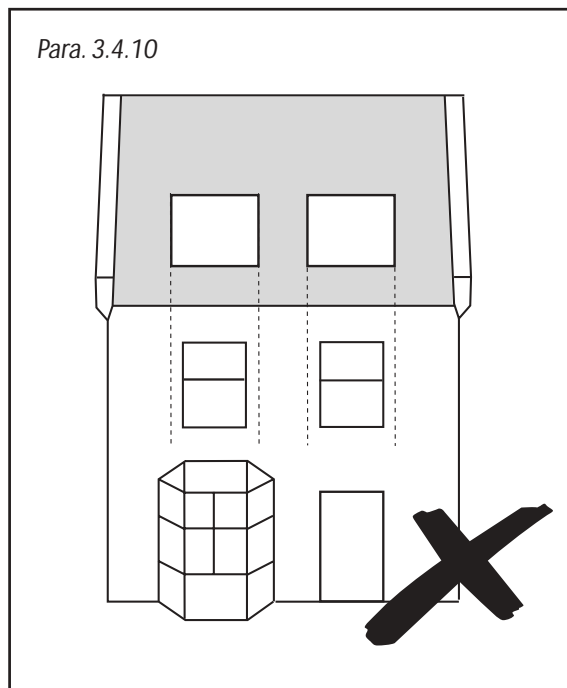

3.4.10. Dormer windows often look better if they are no wider than the windows in the main facade below, and they should not normally be wider than they are high, unless such a form is appropriate to the original architecture of the building.

3.4.11 Dormer windows should normally be centred directly above the centre line of windows in the main facade of the building below. In some cases the architectural style of the building does allow this principle to be relaxed.

3.4.12 Dormer windows should not normally dominate the lines of a roof. It is recommended that a dormer window should not occupy more than about 20% of the area of the roof.

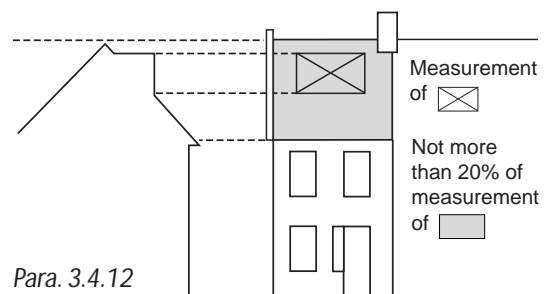

3.4.13 The alteration of a conventional roof with a pitch to the front and similar pitch to the rear, so as to form a mansard type roof form on the rear roof slope would not normally be acceptable. The reason for this is because such a roof form would be alien to the architectural style of the original building and probably to that of its neighbours, and it would create an unbalanced roof design.

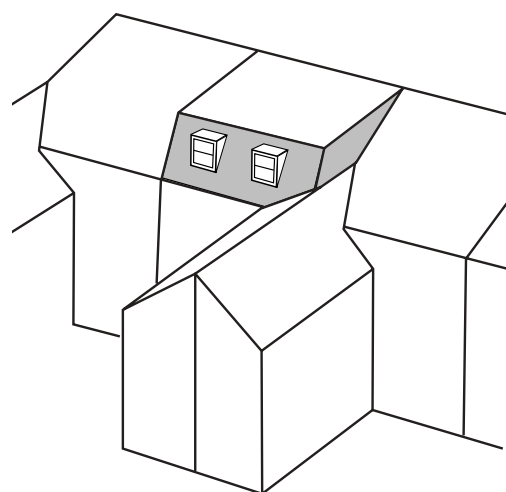

Para. 3.4.14

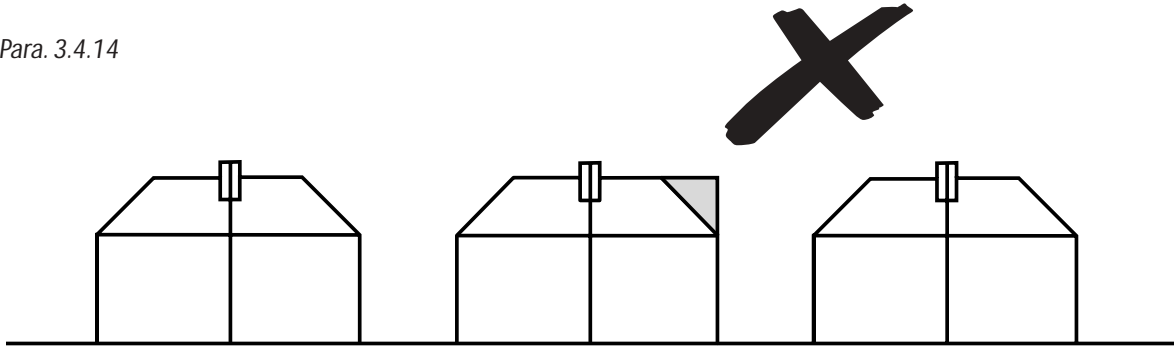

A dormer window extension on the rear roof slope is likely to be a more appropriate form of roof extension in this situation. Extensions using mansard roofs on the rear roof slope may however be acceptable where they would be substantially concealed from neighbouring properties by projecting rear wings or extensions. In these situations the steep mansard roof slope should be at 70 degrees, and all windows set into that roof slope should be set vertically.

3.4.14 The regular repeated rhythm of roof forms may be a feature of an area. In such situations the alteration of a hipped roof to a gable, would be resisted. This is often necessary to help preserve the character of the street scene.

3.5 PRIVACY

3.5.1 Extensions or alterations to a dwelling can have the effect of reducing the degree of privacy enjoyed by neighbouring properties. In particular upper windows can cause overlooking of neighbouring gardens and windows. To reduce the impact of overlooking it is necessary to observe certain minimum separation criteria as indicated in the drawing below.

Greater separation should be maintained for extensions which have windows above 1st floor levels.

Para. 3.5.1

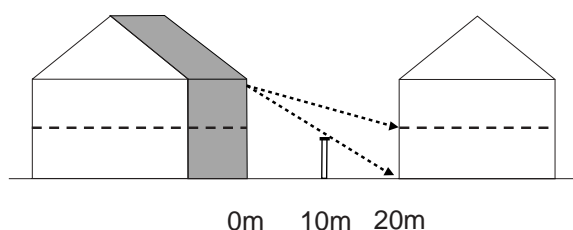

3.5.2 Extensions into the roofspace can, by introducing dormer windows reduce the degree of privacy enjoyed by neighbouring dwellings. A distance of 25 metres between neighbouring properties whose windows face one another is considered to be the minimum distance required for a window at second floor level.

Para. 3.5.2

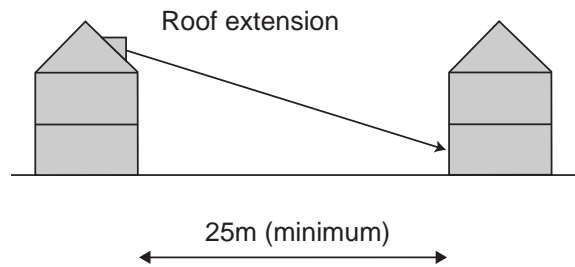

3.5.3 A flat roof over an extension is sometimes intended for use as a balcony. However this can cause severe overlooking problems for neighbouring properties and would not be acceptable.

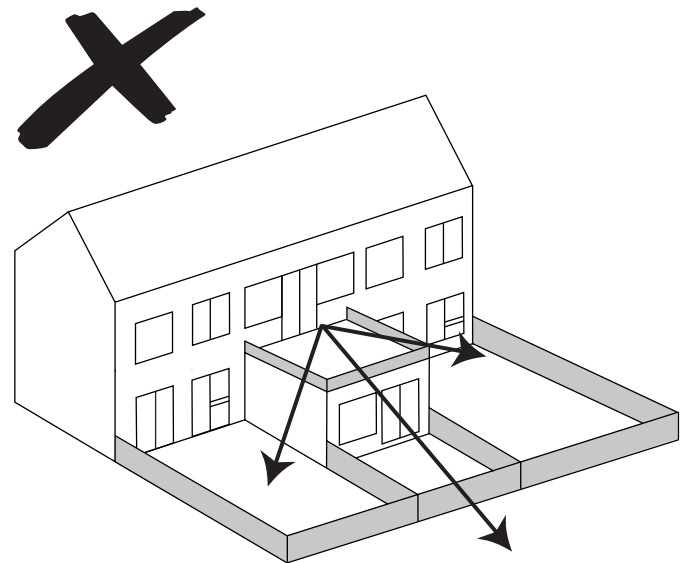

Problems with overlooking

Para. 3.5.3

Para. 3.6.1

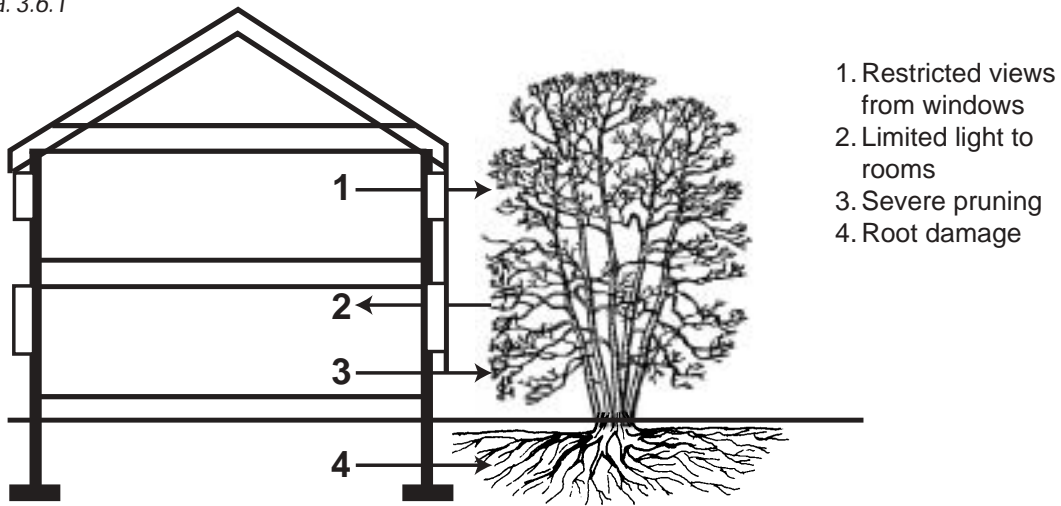

3.6 TREES

3.6.1 Any front, side or rear extension can affect trees, either requiring them to be removed, or reduced in size. Excavations for foundations etc. can also damage root systems, and affect the future health of the tree. Where an existing tree would restrict light to, or views from the window of an extension, this may lead to a future demand for the tree to be removed or reduced in size.

3.6.2 The Council's policy is aimed at protecting trees of amenity value, and where any proposal for an extension affects such a tree in any of these ways, either immediately or at a future date, it will not be permitted.

3.6.3 Some trees in the Borough are protected by Tree Preservation Orders, and works must not be carried out to them until consent has been granted by the Council. For most trees in Conservation Areas six weeks notice needs to be given to the Council before any tree felling or pruning work is carried out. In such cases the Council may decide to issue a Tree Preservation Order.



(Further guidance - Supplementary planning Guidance on Planting landscaping and nature conservation, see contacts List).

4.0 Detailed Design Considerations

4.0.1 As a general rule any extension or alteration to a dwelling will be more successful if account is taken of the detailing on the original building, before changes are planned. Even small items of detailing will make a great difference to the finished building. By taking account of such matters an alteration or extension can be an enhancement to the original dwelling.

4.0.2 Attention to detailed design is considered to be important, especially in Conservation Areas, and proposals may be refused planning permission if inappropriate design details are used.

4.1 ROOF DESIGN

4.1.1 The type of roof on an extension can dramatically affect its appearance. Flat roofs tend not to fit in well with residential properties, and their appearance can be detrimental to the rest of the property. Whilst flat roofs may in the first instance be cheaper than pitched roofs, their maintenance costs are much higher, as they do not collect and distribute rainwater as efficiently as pitched roofs. There is usually the opportunity to avoid flat roofs in most situations, through careful design. Planning conditions are usually imposed where permission is granted for a flat roofed extension. These prevent the installation of water tanks or other plant on the top of the roof.

4.1.2 Roof design and roof slopes should be similar to those on the original property. Hipped roof extensions would normally relate better to hipped roofed buildings, and gabled extensions to gable roofed buildings.

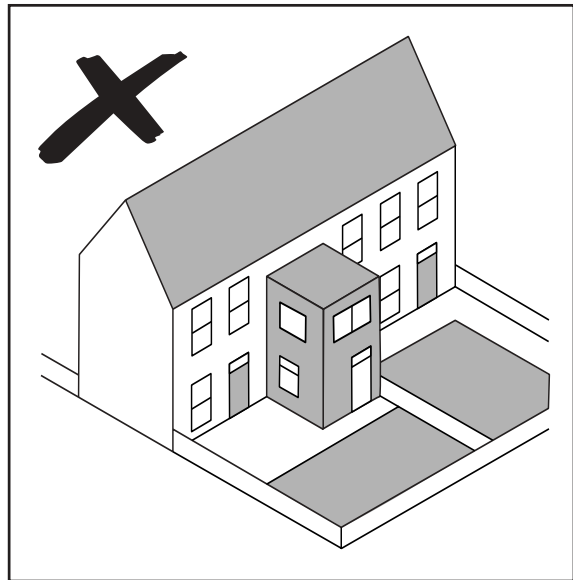

Para. 4.1.1a

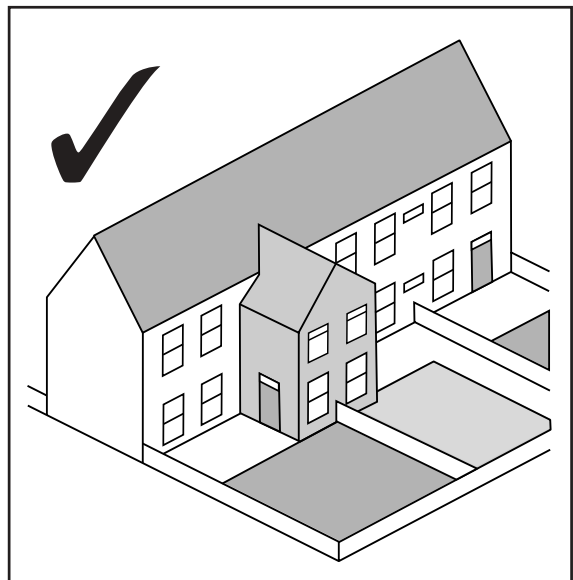

Para. 4.1.1b

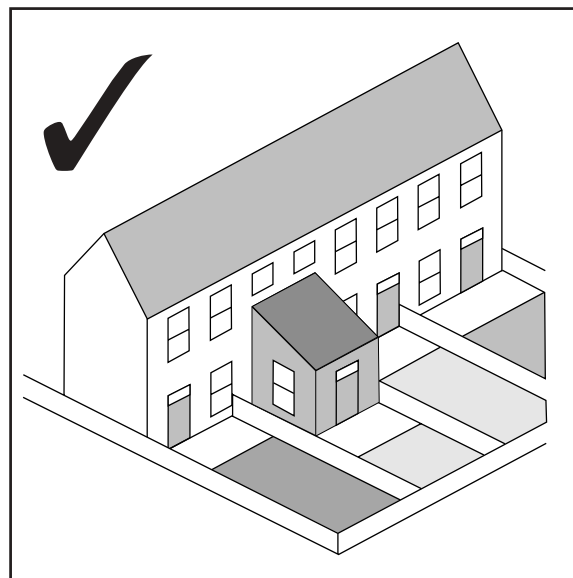

Para. 4.1.1c

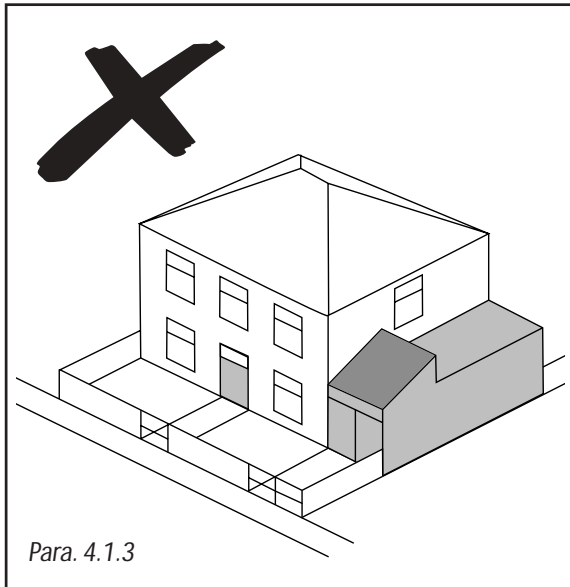

4.1.3 It is almost always unsatisfactory to attempt to conceal a flat roof behind a false pitched roof.

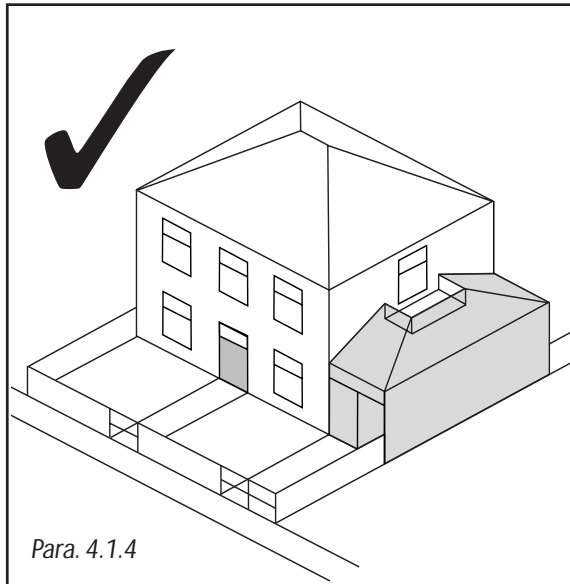

4.1.4 Occasionally, in order to protect an existing window, a more complex roof design may be necessary, however the roof design should appear, as far as possible, as an orthodox pitched roof when viewed at ground level from different angles.

4.2 MATERIALS

4.2.1 The materials used in any alteration or extension should be related as closely as possible to those used in the original building. For the walls in many cases this is likely to mean seeking to obtain the best match of bricks both in colour and texture. This can be more difficult, particularly where original bricks are old and weathered and in the old imperial size.

4.2.2 The colour of mortar used, and the finish to the pointing can make a significant difference to the eventual appearance of brickwork. It is therefore desirable to get a good match with the original brick walls.

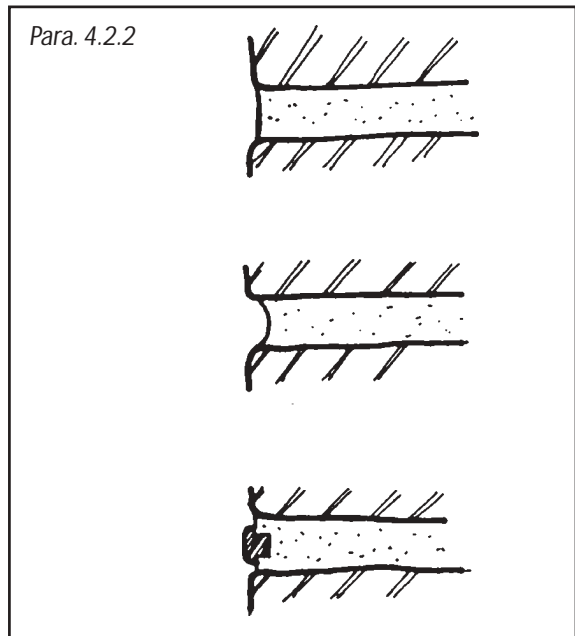

4.2.3 Rendering of exterior walls will not generally produce a satisfactory finish unless the original building is also rendered. Furthermore render does need frequent attention and is thus a maintenance liability.

4.2.4 Cladding with stone, artificial stone, wood or pebbledash always looks wrong for any extension or alteration, unless the original property (and also its neighbours in the case of a street of similar dwellings) use this type of material. Stone cladding has been seen to weather badly, while wood requires constant maintenance and pebbledash becomes dark and discoloured.

4.2.5 Roof materials similar to the original building (or to its neighbours) should be used wherever possible. Often slate or tiled roofs deteriorate only as a result of the rusting of metal fixing nails, rather than the deterioration of the tiles or slate.

These can often be reused if they are carefully removed. Second hand slates are normally available at lower cost than new ones, and these may be able to be used to make good any originals that may be damaged. New slates can be expensive, but cheaper asbestos free artificial slates are available and their appearance may in some cases be acceptable. Textured artificial slates give a more realistic effect than plain ones. When replacing tiles a good match of colour and shape is important. In a terrace of houses, or in semi detached houses, junctions between different roofing materials always cause problems.

4.3 WINDOWS

4.3.1 Windows are an important element that make up the character of the dwelling. If they are altered, or if new ones are added, which differ from the style and character of the originals, then the character of the property may be destroyed. In any new windows that are proposed it is important to echo the proportions (vertical or horizontal). Typically in older houses including Victorian and Edwardian, the windows tend to display a vertical emphasis, while those on more modern property often have a more horizontal emphasis.

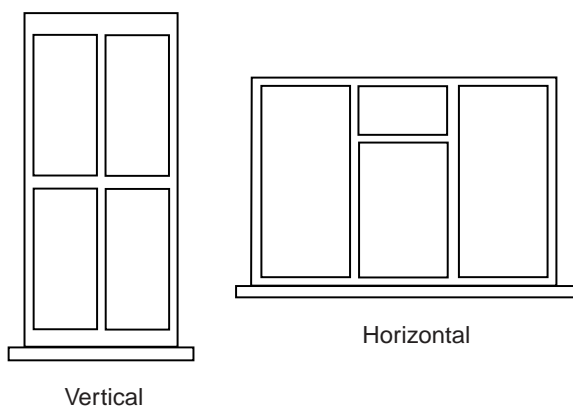

Para. 4.3.1

4.3.2 Windows in an extension should also echo the style and detailing of existing windows (eg sashes, mullions or casement), and should also use similar materials to the original windows (usually wooden frames). The windows for an extension will also generally need to use the same pattern of glazing bars as is used in the windows of the existing building.

4.3.3 In some cases the windows for an extension should be of broadly similar size to those in the existing building, but in extensions following the subordinated approach, they may need to be smaller, (see the section on side extensions).

4.3.4 In most older property windows tend to be recessed, with a reveal. This is important to the character of the building, and it also helps to protect the window from weathering.

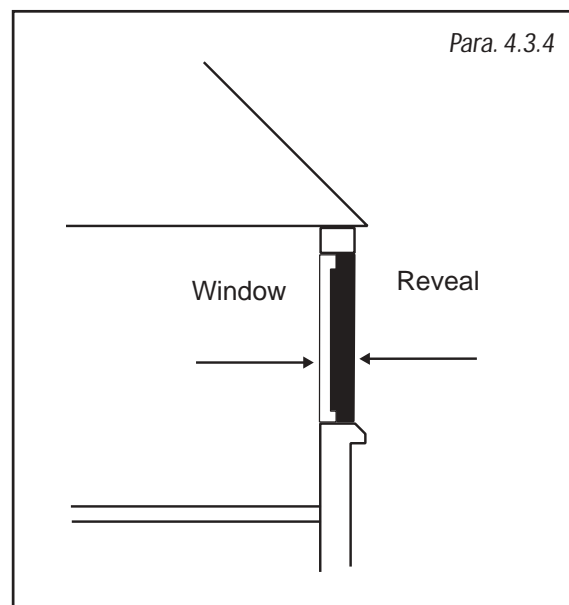

Para. 4.3.4

4.3.5 Repairing original sash windows is usually cheaper than fitting new ones, they may also last longer than a modern softwood window frame which may need replacement after 10 years. Even the popular modern U.P.V.C. window frames are likely to involve future maintenance work. Sash windows should therefore be repaired, rather than replaced, wherever possible. Where this is not possible, they should be replaced to match the original window style and materials of the windows used in the building or the terrace.

4.3.6 Bay windows are a very prominent design feature usually on the front facade of houses of the Victorian/Edwardian and the inter-war period. They provide good natural lighting for rooms, and excellent views to the street. They often display high quality detailing which is an enhancement to the appearance of the dwelling and the street. If they are removed or substantially altered, then this is likely to destroy an important part of the character of the building, and erode the design quality of the street.

4.4 DOORS, PORCHES AND FRONT GARDEN PATHS

4.4.1 Doors, porches and front garden paths can form very important design features at the front of the dwelling. In Victorian and Edwardian properties in particular they are often very finely detailed using high quality materials, with arches, gables, fanlights, pillars, capitals, coloured glazing, tiling and door panelling.

4.4.2 In many cases, particularly with older property, the addition of a new porch or alterations to the existing door or porch can be detrimental to the richness of this detailing. This is often seen when an existing open fronted porch has been enclosed. Once drastic changes of this sort have been carried out, it is often prohibitively expensive to restore the building to its original character.

4.4.3 Doors and porches should therefore be treated in the same way as windows, with the emphasis on repair rather than replacement, and conservation of the good detailing wherever possible.

4.5 DECORATIVE DETAILS

4.5.1 Decorative details help to give a dwelling special character and they are usually particularly notable on older properties, including those of the Victorian and Edwardian period. Such details may include patterned polychromatic brickwork, finials, cornices, quoins, sills, lintels, string courses, decorative tiling, pillars or pilasters

4.5.2 Where a dwelling is to be extended it is important to carry through these items of detailing into the proposed extension, particularly in respect of front or side extensions. Similarly where other alterations are envisaged, the detailing should be replaced, wherever possible salvaging original materials. Quite minor items of detailing can make a great difference to the finished result.

5.0 Residential Conversions

5.0.1 Proposals for residential conversions include the conversion of a residential building into several dwellings, or the conversion of all or part of a building from a non-residential use to form one or more dwellings. The dwellings produced will normally provide for the full and self-contained requirements of everyday living, including a bathroom and kitchen for the sole use of the occupier.

5.0.2 This type of conversion is different from using a house for the purposes of multiple occupation, where occupiers may share facilities such as the kitchen or bathroom, and to which other legislation may apply. Both Planning Permission and Building Regulations Approval will be required for the conversion of any residential property.

5.0.3 Any extensions to a building, or adaptations of roof space to provide additional accommodation should comply with the guidance contained elsewhere in this Note.

5.1 IS THE PROPERTY SUITABLE FOR CONVERSION?

5.1.1 The Council wishes to see conversions occur in only the most suitable properties and to ensure that satisfactory residential standards are obtained.

5.1.2 The size of the building to be converted is the main issue to be considered when developing any conversion proposal as it will affect the number of units of an acceptable standard that can be created within it. Some two and three bedroomed terraced houses are considered to be too small to convert. In these small houses, it is not actually possible to provide flats with rooms of an adequate size, or with sufficient internal circulation space. These houses are therefore best suited for families.

5.1.3 For these reasons, conversion schemes for small houses or buildings with less than 120 square metres of floorspace will not normally be permitted,

where more than one dwelling is proposed. "Floorspace" means existing habitable floorspace, including hallways, landings, stairways, bathrooms and kitchens as well as habitable rooms. It does not include cellars, vaults or non-habitable basements, roof space or detached outbuildings. The measurement of floorspace should be calculated based on an aggregation of internal measurement of individual room sizes (excluding all space occupied by internal and external walls).

5.2 LAYOUT OF CONVERSION SCHEMES

5.2.1 House conversions which alter the internal and external fabric of the building as little as possible tend to be the most satisfactory.

5.2.2 All flats must be self-contained. They must each have their own private entrance doors which lead either directly from the street or off a common entrance hall.

5.2.3 Entrance doors to flats must also open into a lobby or hallway.

5.2.4 The larger or largest unit should be preferably located on the ground floor. Where flats suitable for families are proposed (ie those with three or more bedrooms), a safe and convenient access to a garden that is suitable for pushchairs and prams will be required.

5.2.5 Conversions which provide an additional unit wholly in the roof space, will similarly not normally be permitted.

5.2.6 Habitable rooms must be able to function for the purpose of which they are intended. They must be of an adequate size, shape, and height, and have both natural lighting and natural ventilation. The definition of a habitable room is a room which is used mainly as a living room, dining room or bedroom or as a kitchen when it is larger than 13 sq. metres. A dining space which is separated from the kitchen or living area by a movable partition would also be considered as a habitable room.

5.2.7 Internal kitchens are not usually considered desirable. The configuration of the room should provide for a reasonable layout of services and equipment.

5.2.8 It is preferable to keep a permanent partition between eating and sleeping areas in all flats. For smaller flats, combined kitchen dining and living areas may be acceptable as long as the floor area is sufficient to take account of the greater range of household activities carried on in them. However, in family flats (all units with three or more bedrooms) kitchens and living rooms must be permanently separated.

5.2.9 Where cooking and eating areas are not provided in the same room, then the kitchen and dining areas should be close to each other, affording a safe and convenient passage to carry food between the rooms.

5.2.10 All rooms in a flat should lead off a hallway or lobby. It should be possible to enter and leave one room without passing through any other room.

5.2.11 Storage space should be provided in conversions. Recesses and otherwise unusable spaces should be put to good use within flats where additional storage space is in short supply.

Consideration should be given to the use of basements or other areas not being used for living accommodation.

5.2.12 Entrances should be via the front of the building, with front doors easily accessible and open to surveillance from the street.

 (Further guidance - Supplementary planning Guidance on Designing Out Crime, see Contacts List).

5.2.13 In order to cater for the requirements of people with special needs, where the configuration of the building allows, all dwellings will need to be designed flexibly to cater for occupants as their needs change.

 (further guidance - Supplementary Planning Guidance document on Accessible Environments, see Contacts List)

5.2.14 Residential conversions should not create flats that only have a north facing aspect. Double aspect properties are preferred so that the flat can receive an adequate amount of sunlight, and to provide the occupier with a variety of outlooks. Windows of habitable rooms should preferably look out onto some form of amenity space.

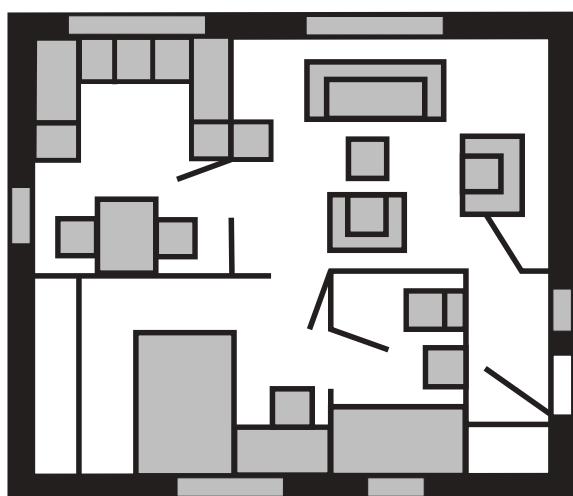

Flat with poor circulation
Para. 5.2.10a

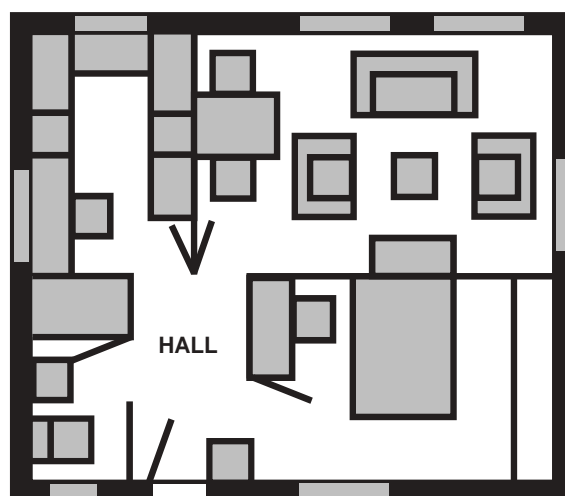

Flat with better circulation
Para. 5.2.10b



5.3 SPACE STANDARDS

5.3.1 In assessing applications particular attention will be paid to the Council's room size criteria.

5.3.2 Room sizes in excess of minimum standards will be sought to ensure that the dwellings created in conversion schemes are adequate for the functions which they are intended for.

All rooms should be of a size and shape which allows a satisfactory layout and adequate range of furniture and equipment. Applicants may be asked to demonstrate the adequacy of proposed habitable rooms by providing details of possible furniture layouts.

5.3.3 Rooms should preferably have a headroom of at least 2.3 metres over at least half of the floor area. The calculation of floor areas in relation to the minimum room sizes will ignore any areas with a headroom of less than 1 metre.

5.3.4 The room size standards in the table below are widely used by London Planning authorities, and are designed to ensure that the rooms are of an

adequate size, to meet modern requirements. Accommodation should be proportionate to the number of occupants.

5.3.5 Bedrooms should be capable of accommodating built-in cupboards on internal walls. The planning of bedrooms should also keep in mind the possibility of them being used as secondary living spaces, (eg for studies and watching TV).

5.3.6 Bathrooms should be a reasonable size to provide for a good layout of fittings, usually a minimum of 5 square metres. Internal bathrooms should have mechanical ventilation.

5.4 AMENITY SPACE AND BIN STORES

5.4.1 All larger flats of two or more bedrooms will need to have direct access to a garden, or shared amenity area, which should be in the form of a consolidated usable space, and should have a minimum size of 10 square metres per habitable room. This space should enjoy a high degree of privacy from the public street and from any other public places.

Table A - Minimum Room Sizes (All Figures in Square Metres)

Number of persons (based on bed spaces)	1	2	3	4	5	6	7	8
Main Bedroom	8.5	11	11	11	11	11	11	11
Other Double Bedrooms	-	-	-	10.5	10.5	10.5	10.5	10.5
Single Bedrooms	-	-	6.5	6.5	6.5	6.5	6.5	6.5
Dining Room	6.5	6.5	6.5	6.5	7.5	8.5	9.5	10.5
Living Room (with Dining Kitchen)	11	12	13	14	15	16	17	18
Dining Kitchen	8.5	9.5	11	11	12	13	14	15
Galley Kitchen	5.5	6	6.5	7.5	7.5	7.5	9.5	9.5
Living Room (without Dining Kitchen)	14	15.5	17.5	17.5	19.5	21.5	21.5	23.5
Combined Living/Dining Kitchen Area	18.5	18.5	-	-	-	-	-	-

5.4.2 Access to a shared garden area through bedrooms will not normally be acceptable. A private garden area for each flat is preferable (provided the division of the garden does not adversely affect the characteristics of the surrounding area) although communal garden space may be provided where satisfactory access can be obtained and where the privacy of ground floor occupiers is not affected.

5.4.3 Where amenity space adjoins a public street (eg in front garden areas), suitable landscaping provision should be made when it is currently lacking or is deficient. This should be sufficient to screen any car parking spaces and bin stores, and to soften the lines of the building.

5.4.4 Where walls, fences or railings are to be rebuilt care should be taken to keep the original character, height and materials. In all cases walls, fences or railings should be designed to maintain or improve the outlook, privacy, safety and security of flats and adjoining properties and allow for informal surveillance of the street from the windows.

5.4.5 Trees of amenity value should always be retained.

5.4.6 Where the larger or largest flat cannot be accommodated on the ground floor an external staircase may be considered in order to gain direct access to the amenity space. However it would be preferable to gain such access internally. External staircases need to be carefully designed to avoid the problems of loss of privacy and loss of outlook and should not create a problem of security for other residents. Staircases should be no more than one storey in height and should be constructed in materials which complement the existing building.

5.4.7 **Escape staircases may be required under Building Regulations, and advice should be sought from the Building Control Section of the Environmental Services Dept. (see Contacts List).**

5.4.8 Storage facilities for household waste should always be catered for in residential conversion

schemes. Enclosed bin stores should therefore be constructed in a suitable location, preferably behind boundary walls. Stores should be provided at a rate of at least 0.5 square metres per dwelling.

The enclosure should be constructed in attractive materials, and should be designed so that it is not obtrusive. The use of planting and landscaping can often help hide such facilities. Locations close to ground floor windows should always be avoided.

5.5 CAR PARKING

5.5.1 Car parking will be a major consideration when a residential conversion scheme is proposed. The Council does not consider that a uniform standard should be set for the number of spaces that should be provided, but that the number of off street parking spaces and their design should be appropriate to the units being created and to the characteristics of the locality. This will include consideration of the previous use of the building, and the car parking demand that use generated, the availability of public transport facilities, the availability of on street car parking spaces, and the status of the road in which the development is situated.



(Further guidance - Supplementary Planning Guidance on Traffic and Parking, see Contacts list).

5.5.2 Applications may be refused permission if, according to the above criteria, off street car parking provision is required, but it could not be provided without damage to residential amenity or the character of a Conservation Area.

5.5.3 Where off-street parking places are to be provided, then special attention should be given to their layout and design, and they will only be acceptable where there is no worsening of residential amenity. Additional parking in rear gardens should be avoided, and parking in front gardens should be adequately landscaped. Preferably car parking spaces should not be located immediately adjacent to the ground floor windows of habitable rooms. Special consideration will need to be given in Conservation Areas where parking in front

gardens could seriously damage the character of the area.



(Further guidance - Design Guidance on Front Garden parking, see Contacts List)

5.5.4 Where the parking requirement for a conversion scheme necessitates using a large proportion of the total front amenity area, this will be taken as being indicative of over development of the property.

5.5.5 A minimum space of 4.8 m by 2.4 m will be required for each parking space to be provided, or 4.8 m by 3.0 m for spaces for people with disabilities. These should be designed and landscaped to provide a serviceable area for the vehicles and complement the original garden design. Where possible they should also be overlooked from the windows of the dwelling that the parking space is to serve, although they should not be over obtrusive.

5.5.6 Crossovers to the highway are also required to service off-street parking areas and these must be properly constructed to the Council's satisfaction. Separate permission from the Council should be obtained to construct dropped kerbs or crossovers, if access to off-street parking is across a public footway. To this effect you are advised to contact the Council's Street Management Division (see Contacts List).

5.5.7 On major roads such as trunk roads and classified roads, planning permission will also be required for crossovers.

5.5.8 Direct access across the footway will not normally be permitted if more than two car parking spaces are positioned side by side.

Para. 5.5.8

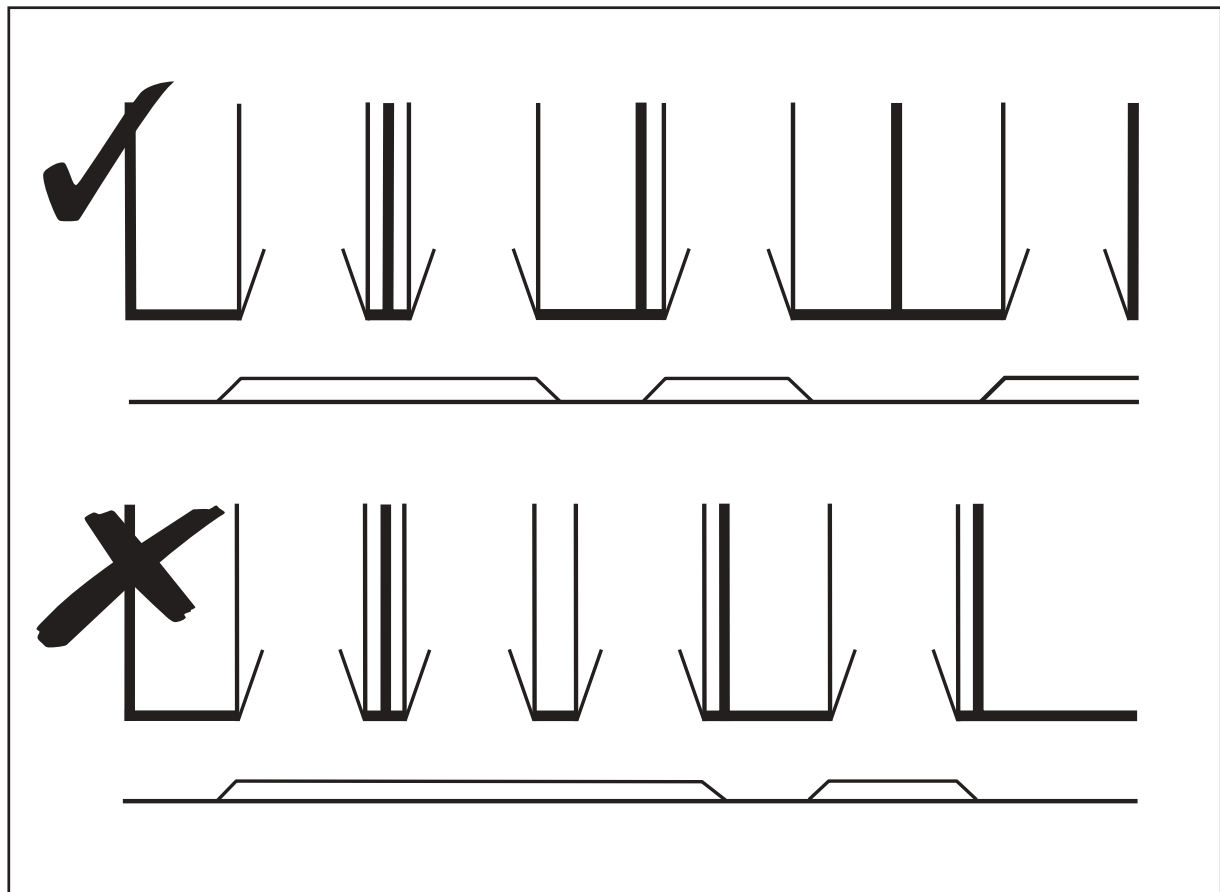

5.6 SOUND INSULATION

5.6.1 The stacking and layout of rooms within a conversion scheme should seek to minimise the effects of noise generation on neighbour's rooms.

5.6.2 In all conversions the layout of the flats should preferably be designed such that rooms in different flats on different floors which are intended for similar purposes are in vertical alignment i.e. the conversion would result in an acceptable stacking arrangement (bedrooms above bedrooms living rooms above living rooms).

Achieving a successful stacking arrangement would also apply where part of one flat is on the same floor as another flat.

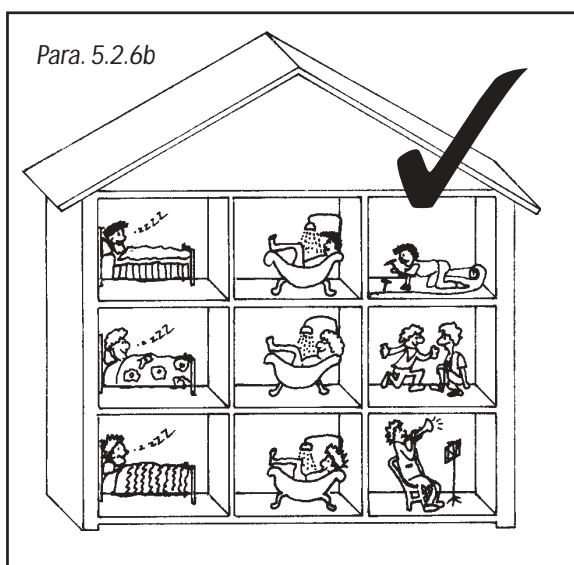
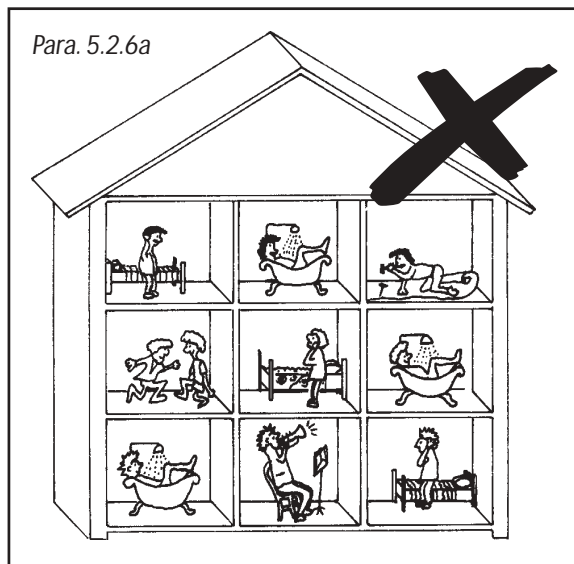

5.6.3 Sound insulation between all flats will be required under Building Regulations in every conversion scheme.

5.6.4 In the assessment of conversion proposals for noise sensitive development, where a change from one use to residential use is involved, three noise levels will be considered as follows:

5.6.5 Noise Level A. The level below which noise need not normally be a material consideration in determining an application is 55 dB, Laeq.

5.6.6 Noise Level B. Levels in excess of level A above will require noise sensitive development to be provided with an adequate measure of external insulation.

5.6.7 Noise Level C. There should be a strong presumption against residential developments which are, or are expected to become, subject to a noise level in excess of 70 dB, LAIO (18 hrs).

5.6.8 Where premises adjoining commercial premises are to be converted from one use to a residential use, then a higher standard of noise insulation than that required by Building Regulations may sometimes be necessary. In these situations developers are advised to contact Environmental Health officers for detailed advice (see Contacts List).

5.6.8 Where noise emission is indicated from an industrial source, regard will be had to BS 4142 in determining the impact of such noise.



(Further guidance - British Standard 4142, see Contacts List)

5.6.9 There are two types of noise source that must be considered, namely airborne sound and impact sound.

5.6.10 Airborne sound is noise that travels through air and lightweight building materials, such as music and people talking loudly.

This can be reduced by:

- (i) using a heavier type of building material,
- (ii) introducing a secondary wall or floor to an existing structure, or,
- (iii) building a double skinned structure.

5.6.11 Impact sound is noise caused for example by footsteps from the flat above which causes the structure to vibrate.

This type of sound can be prevented by constructing floors and ceilings to prevent a direct path through which the sound waves can travel.



(Further guidance - noise insulation - Report on Sound Insulation in Flat Conversions Parts 1 and 2 National Society for Clean Air - Noise Committee June 1986 and January 1987.



Building Research Establishment Technical Information Leaflet No.42 - a Method of Improving the Sound Insulation of Party Walls, 1982.



Building Research Establishment Technical Information Leaflet No. 68 - a Method for Improving the Sound Insulation of Existing Floors between Two Dwellings 1982.



Building Regulations 1992 and Approved Document.



Risks and Remedies - Noise: The Remedies - Architects Journal 10th February 1988. (See Contacts List)

5.6.12 Examples of preferred methods of construction are shown in the 1992 Building Regulations Approved Document.

It is, however, accepted that in certain circumstances there may be practical difficulties in adopting these methods and alternative proposals may be accepted.

The Council will also generally find proprietary systems such as Reduc Board, Gyproc, etc. acceptable, so long as they are installed satisfactorily.

5.6.13 Party floors need to be constructed to resist the transmission of both airborne and impact sound. The floor must be designed to prevent vibrations travelling into the structural base and walls and must minimise the likelihood of flanking transmission.

5.6.14 Five examples of measures which may be taken to provide adequate party floor noise insulation are illustrated in the 1992 Building Regulations & Approved Document.

5.6.15 The main principle is to leave a narrow gap between the floor and skirting and to float the floor on a resilient layer of material such as glass fibre, mineral wool or certain types of polystyrene. It is important that pipes & nails do not pierce this layer and that there is no fixing between the floating floor and the structural floor or skirting board.

5.6.16 The resilient layer should be continuous across the base and turned up at the edges between the floor and the walls. A separate floating floor should be provided for each room.

5.6.17 It is important to ensure that as far as possible, party walls resist the transmission of airborne sound.

5.6.18 The construction of a secondary leaf, consisting of two layers of plasterboard on stud work adjacent to the existing wall, generally gives a reliable standard of noise insulation.

5.6.19 Examples of measures which may be taken to provide adequate party wall noise insulation are illustrated in the 1992 Building Regulations & Approved Document. Alternative designs may be acceptable where

it can be demonstrated that an equivalent noise insulation performance would be achieved.

5.6.20 These measures are by no means comprehensive and attention must also be paid to reducing noise transmission through staircases, corridors, service ducts and installations, such as pipes and wires. Unless adequate attention is paid to these aspects, flanking sound can often reduce the benefits of other noise insulation measures.

5.6.21 The Council reserves the right to inspect the noise insulation work during construction and to carry out noise insulation tests when the work is complete.

5.6.22 Timber stairs are subject to the same sound insulation requirements as floors. The sound insulation depends on the resilience of the stair covering, the mass of the stair, the mass and insulation of the independent ceiling or air tightness of the cupboard enclosure. Examples of measures which may be taken to provide adequate stair insulation are illustrated in the 1992 Building Regulations & Approved Document.

5.7 PARTY WALLS

5.7.1 If alterations are proposed to a party wall, or which could affect its foundations, it is essential under the Party Wall etc. Act 1996 to inform the adjoining owner. Details concerning this Act are set out in a leaflet produced by the Dept. of the Environment, which is obtainable from the Building Control Section of the Environmental Services Dept. (See Contacts List).

6.0 Contacts

.....

Plans And Projects

For advice on the Merton Unitary Development Plan, all Supplementary Planning Guidance Notes, Conservation Areas and Listed Buildings, Design Guides for Conservation Areas and other Special Areas
(Tel 020 8545 3074)

Development Control

For advice on the need for planning permission, and for the leaflet "Planning - A Guide for Householders" (DoE March 1996)
(Tel 020 8545 3238)

Building Control

For advice on Building Control issues, for the leaflet "Building Regulations - Explanatory Booklet" (DETR July 1998), for the leaflet on the Party Wall etc. Act 1996, and on Building Regulations matters relating to noise and sound insulation
(Tel 020 8545 3123)

Trees

For advice on Tree Preservation Orders and tree work
(Tel 020 8545 3815)

Crime Prevention

For advice on crime prevention measures
(Tel 020 8649 3070)

Street Management Division

For advice on crossovers
(Tel 020 8545 3829)

Environmental Health

For advice on Environmental Health noise insulation measures
(Tel 020 8545 3025)

www.merton.gov.uk

6.1 Appendix

.....

CONSIDERATION OF REPRESENTATIONS MADE ON THE SPG, FOLLOWING CONSULTATIONS.

This Supplementary Planning Guidance document was placed on deposit as one of the Draft Unitary Development Plan documents at the 1st Deposit stage of the UDP Review Process. This took place in September/October/November 1999.

As a result of the consultations, just one representation was lodged on this SPG document.

Representation

A distinction should be made between the 'material' and 'non material' planning issues which were raised in the SPG.

A checklist format for the document should be considered

The SPG did not give enough emphasis to specification of clear standards (daylight, sunlight and privacy), and too much emphasis on matters of taste and appearance.

Council Response

The comment in respect of 'material' and 'non material' planning considerations has been accepted, and the text of the SPG now makes clear those parts of the SPG which are material planning considerations, and those which are not.

It is considered that given the complexity of the subject, that a checklist format would be insufficient to adequately deal with the issues.

No change has been made in respect of this aspect of the representation, however illustrative material has been added to the SPG to facilitate its use.

It is considered that the balance of the SPG in respect of standards relating to daylight, sunlight, privacy etc. on the one hand, and design and appearance on the other is satisfactory, and no further amendment in this respect have been made.

If you require a translation of this document,
please contact:

এই ডকুমেন্টটির একটি অনুবাদ যদি আপনি পেতে
চান তা'হলে অনুগ্রহ করে যোগাযোগ করুন:

如果閣下對這份文件需要翻譯
請聯絡：

જો તમને આ દસ્તાવેજનું ભાષાંતર જોઈતું હોય તો,
મહેરબાની કરી સંપર્ક સાધો:

यदि आपको इस दस्तावेज़ के अनुवाद की आवश्यकता है तो,
कृपया सम्पर्क करें:

ਜੇਕਰ ਤੁਹਾਨੂੰ ਇਸ ਦਸਤਾਵੇਜ਼ ਦੇ ਅਨੁਵਾਦ ਦੀ ਲੋੜ ਹੈ ਤਾਂ,
ਕਿਰਪਾ ਕਰਕੇ ਸੰਪਰਕ ਕਰੋ:

இத்தகவல் பத்திரத்தின் மொழிபெயர்ப்புப்
பிரதி உங்களுக்குத் தேவையாயின்
தயவுசெய்து தொடர்பு கொள்ளவும்:

اگر آپ کو اس دستاویز کے ترجمہ کی ضرورت ہے، تو برائے مہربانی
رابطہ قائم کریں:

020 8545 3060

(9am - 5pm)

For information on **Supplementary Planning Guidance Notes & Planning Briefs**, for people who are visually impaired, please telephone **020 8545 3060**. Information can be provided in large print. For enquiries from members of the public with hearing impairments, a minicom facility is available on **020 8545 3245**.