

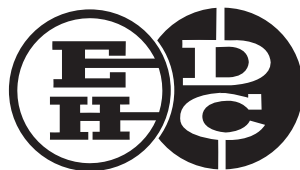

# Extending Your Home

DESIGN GUIDE FOR  
RESIDENTIAL EXTENSIONS

**EAST HAMPSHIRE**



***Partners***

[www.easthants.gov.uk](http://www.easthants.gov.uk)

# DESIGN GUIDE FOR RESIDENTIAL EXTENSIONS

Thinking of extending your home? This design guide has been produced to help you plan your extension by identifying the key points to consider in order to achieve a successful design.

Please read this leaflet before submitting your planning application.

The guide is based on design policies within the East Hampshire District Local Plan, which encourages good design. The design guide acts a supplement to the Local Plan and provides you with further information; Planning Officers will be pleased to give you further advice if this would be helpful.

The District Council must take into account the effect which any proposed extension may have on neighbouring households and the appearance of the area where you live. The principles outlined below will be used in assessing applications; however, each case will always be considered on its merits.

Good design does not always mean greater cost. Employing an architect and using better materials may cost more to start with, but in the long term a well designed and constructed extension will cost less to maintain and is more likely to increase the value of your house.

Many villages have adopted or are working on Village Design Statements. These offer practical advice on design issues particular to the locality. Information about Village Design Statements can be obtained through Parish Councils or the Council's Planning Services.

# BEFORE YOU START

Before you start planning your extension always check with the Planning Officers whether there are any size restrictions on new buildings in your area. For example, if you live outside the policy boundaries shown in the East Hampshire District Local Plan then extensions of up to 50% of the original size of the building or 100 square metres (whichever is the greater) will normally be permitted but larger extensions will generally not be allowed.

Before designing an extension look carefully at your home :

- **has it been extended before?**
- **is it capable of taking a further extension?**
- **is your plot large enough for an extension?**

Decide what makes up the character, appearance and setting of your home. The general form of the extension, the roof pitch and eaves details, its profile/outline, materials used, positions of windows and doors and their details should all relate to the original building and the existing street scene and building patterns.

Is the size of an extension going to adversely affect your neighbours - will it overshadow them or cause loss of light to existing rooms?

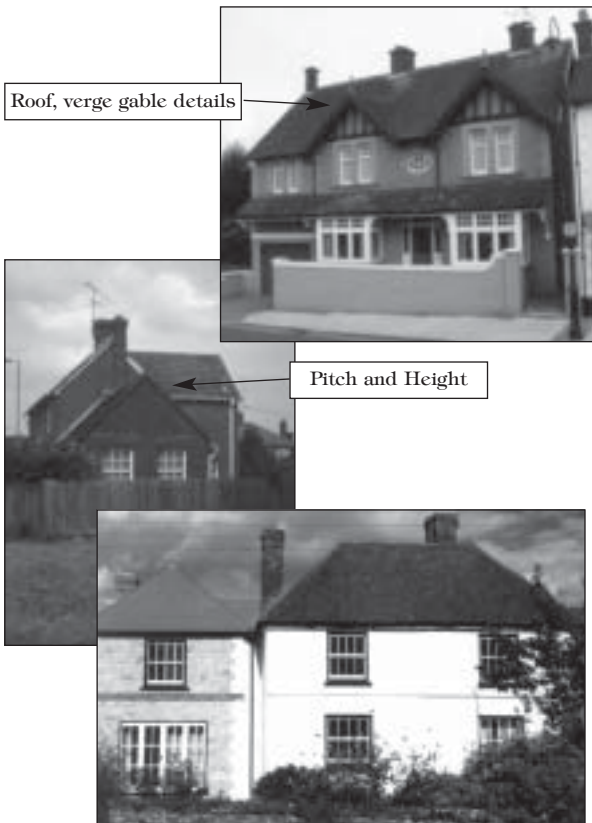

Extensions should always appear smaller in mass and scale to the main building. Generally extensions should look as if they could be part of the original design - although very skilful and imaginative “modern” designed extensions can also be successful.

Has your house been extended in the past and can it accommodate further extensions? For example if you live in the countryside you may not be able to add on as much additional floorspace as you would like due to restricted planning policies; an extension should not dominate the existing building in shape or size.



Has your house been extended before?



# OLD BUILDINGS

If your building is listed as a building of Special Architectural and/or Historic Interest you will also need to consider carefully the effect of the extension on the interior historic plan form. The extension should not obscure the historic value of the internal arrangement of the building.

An extension should not be placed in a position which would result in the loss of the original timber framing, windows, doors, masonry walling or features of intrinsic merit.

The setting of Listed Buildings is important. It is not simply a question of preserving an attractive view. It is important to protect the original use and function of the buildings so that their special character remains.

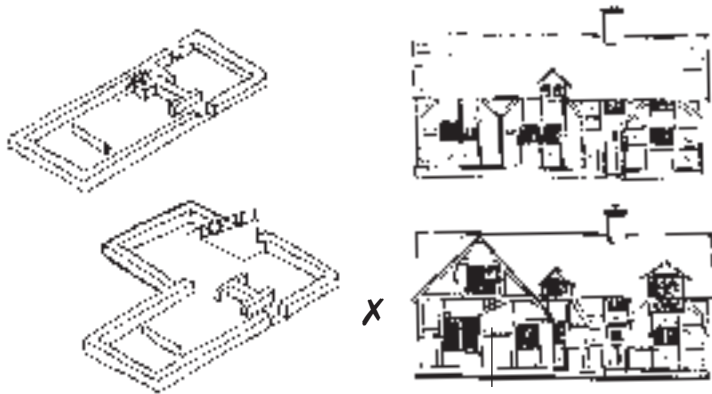

**Extension**

- Scale too big
- Too dominant over original
- Mock frame scale not sympathetic
- Plate glass windows inappropriate
- Obscures much of original building

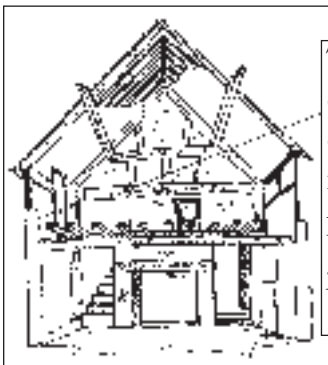
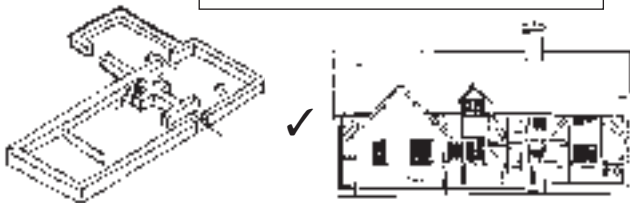

The cutting of new openings through original stud or timber framework, wall plates, tie beams or girding beams should be avoided.

In some cases the character of small cottages can be compromised by the provision of detached garages or two storey extension, this spoils their scale and balanced nature.

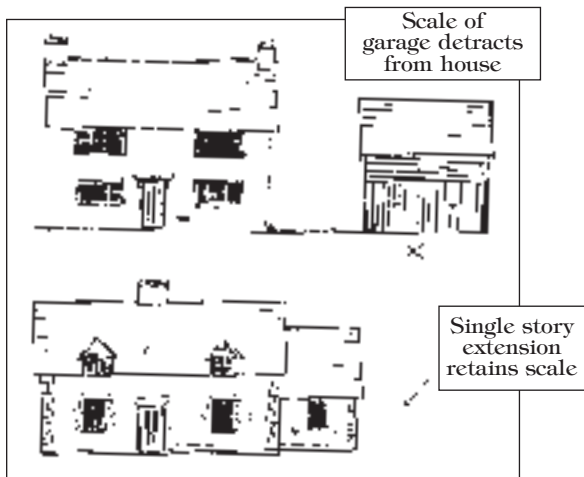

Extensions should not obscure or spoil a well designed elevation or unbalance an existing one; an extension should harmonise with the composition of the building.

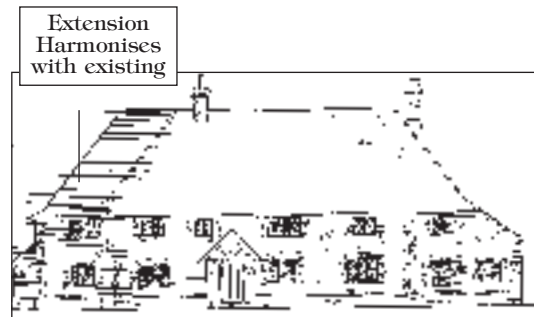

## TRADITIONAL BUILDING EXTENSION FORMS

There are a variety of traditional building forms suitable for extensions, some of these are shown below.



'T' Shape

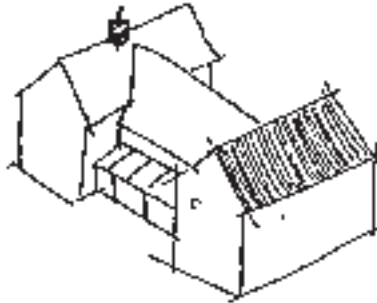

'T' Shape Cross Wing

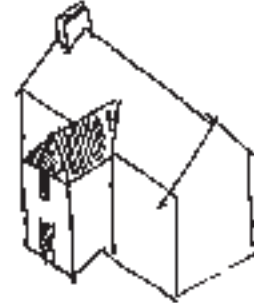

Full Height narrow extra porch

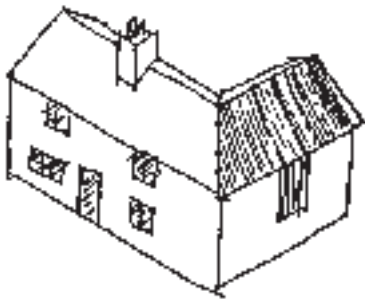

'L' Shape hipped roof



Lean to

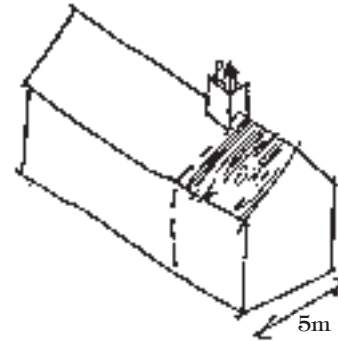

End extension to narrow building



'M' Shaped

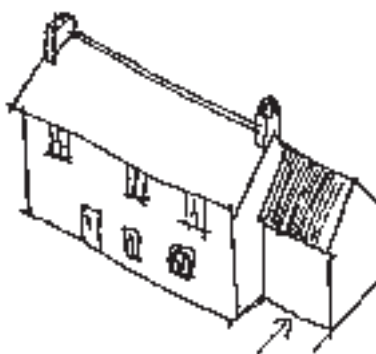

Set back from facade

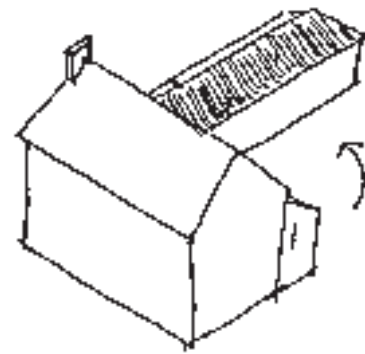

Single storey courtyard



Double 'M' to rear

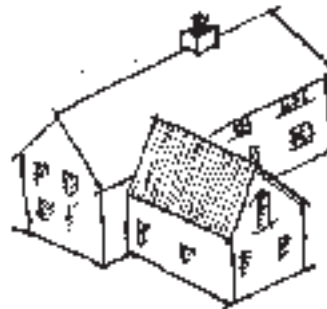

'L' Shaped offset to rear



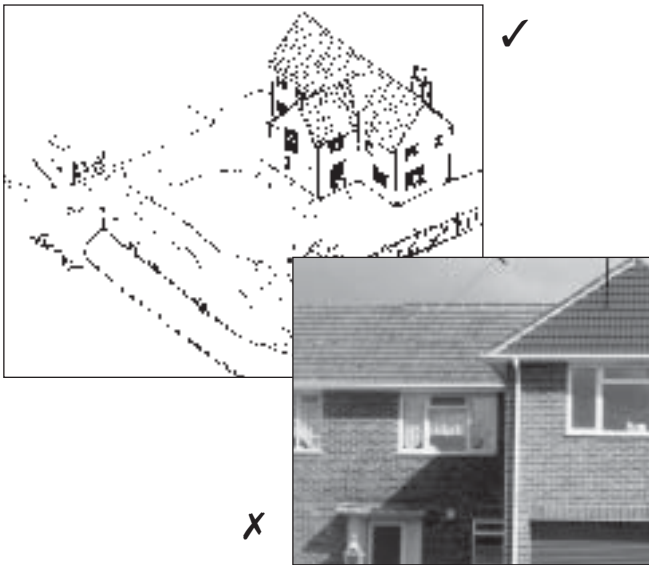

## FRONT EXTENSIONS

Front extensions will normally only be accepted on dwellings located well back from the road, in isolated countryside locations or where there is a staggered building line and pattern in the street.

In all cases they should not stick out too far, or be prominent in the street. Two storey front extensions can only be accepted where the house is set well back from the road and is well screened.

Front extensions should be well designed to avoid disfiguring the face of the house. On corner sites particular attention should also be given to how the side of the extension is treated.



## SIDE EXTENSIONS

### Two Storey

Two storey side extensions should not normally be closer to the side boundary than 2 metres depending on the building line. The character of an area is created as much by the spaces between and about houses as the houses themselves. It is therefore important to retain gaps between houses to respect the character of the area and give separation between houses and avoid a terracing effect.

Two storey extensions should have fully pitched/ tiled roofs to match the existing house. The angle of the roof should be the same as, or as close to, the angle of the existing roof. Flat roofed two storey side extensions will not normally be permitted.

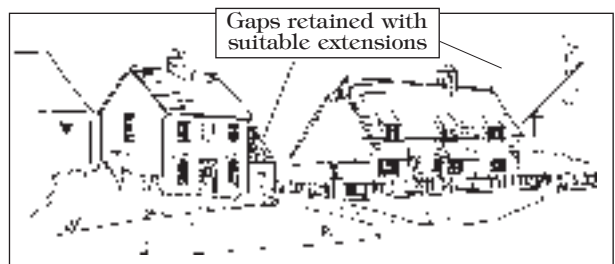
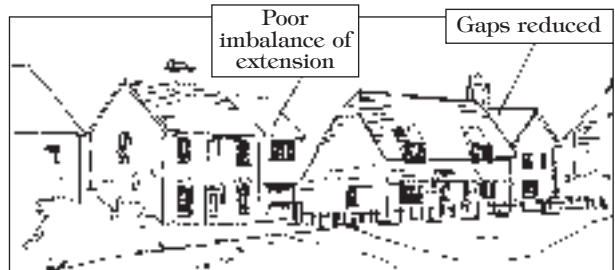



Two storey side extensions generally should not be flush with the front main wall of the house but should be set back slightly.

It may be necessary to have a reduced ridge height for a two storey side extension in order to lessen its impact on the street scene and to ensure that the extension does not dominate the original building.

STREET SIDE

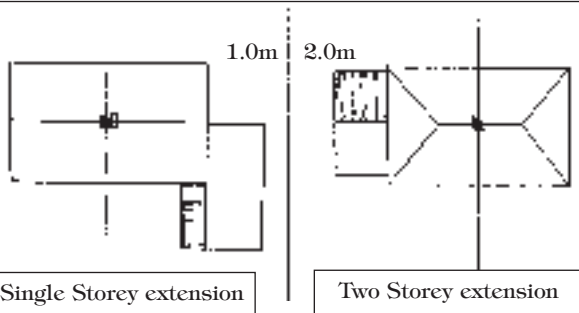

*Minimum distance between Extensions to properties in the same building line*

### Single Storey

Single storey extensions should be set at least 1 metre from the boundary to allow access to the rear and allow for maintenance to the building.

The roof should accord with the design of the existing building and reflect the character of the area. Particular attention should be paid to roof pitch. Flat roof extensions are almost always unacceptable, unless the design of the original building warrants it.

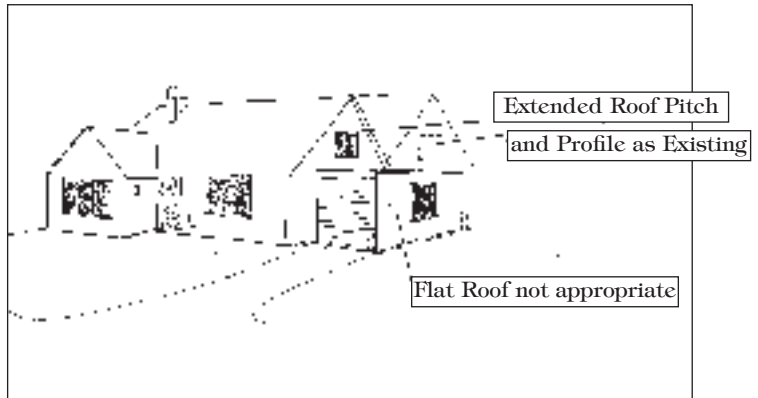

It may be possible to increase the size of the extension by “wrapping” it around to the rear of the property.

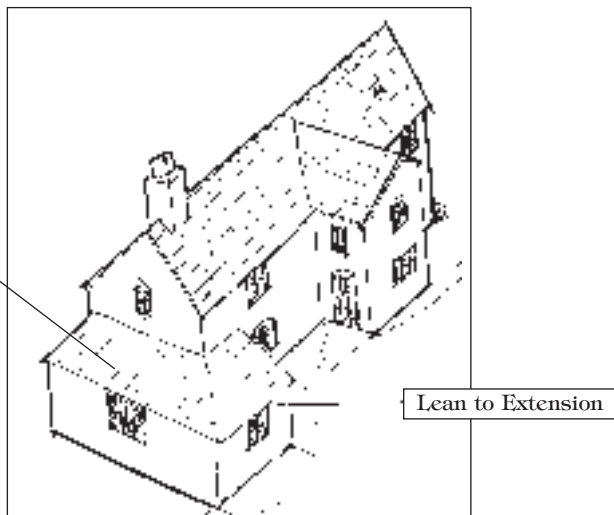

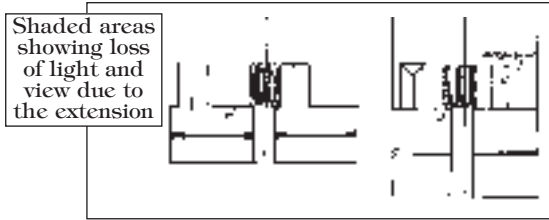
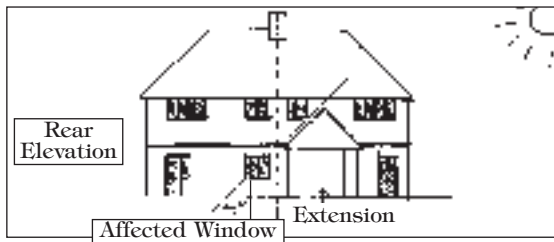

Wide frontages are more able to take extensions than deep

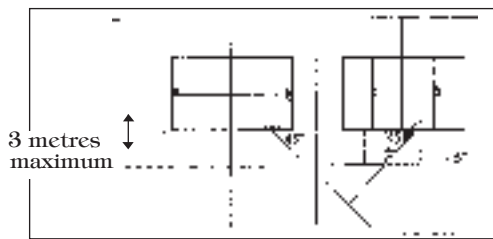

FIRST FLOOR EXTENSION  
Shaded areas affected by extension on adjoining property 45° at mid ground floor window

# REAR EXTENSIONS

Particular attention must be paid to ensure that there is no overshadowing or adverse effect on neighbouring properties.

Rear extensions will normally be permitted up to a maximum distance of 3 metres from the rear wall of the existing house, depending upon its relationship to adjoining properties.

Two storey rear extensions will not normally be permitted within 2 metres of a party boundary, depending on the building line.

Extensions will not normally be permitted if the distance between the extended house and the rear boundary is reduced to less than 8 metres, or if there is less than 20 metres between the wall of the extended property and the property to the rear.

# DORMER WINDOWS

Dormers should primarily be seen as a means of providing light and ventilation to an existing roof space and not to provide headroom. To avoid looking top heavy and spoiling the appearance of the building dormer windows should either be of a similar size or be smaller than the windows below.

Dormers should either sit on the wallplate or should be set well into the roof, back from the front line of the wall below, in from the verge and below the existing ridge line. They should not dominate the roof, and must retain the majority of the existing roof slope.

Dormers should normally have pitched roofs with slopes in keeping with the existing roof.

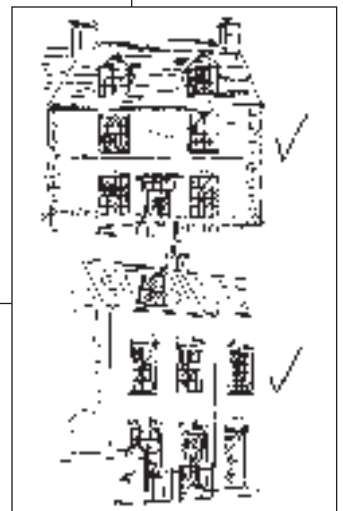

Large and box dormers should be avoided





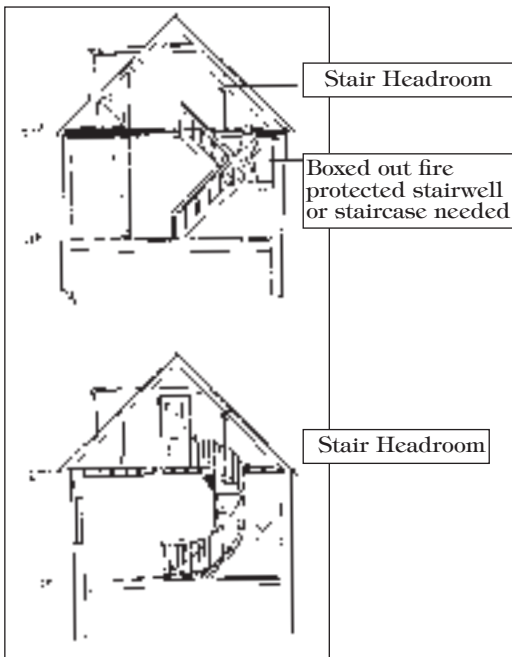

In some cases, where there is sufficient headroom within the existing roof, windows in gable walls or rooflights may be all that is needed and dormer windows may be refused planning permission.

Rooflights in the roof slope fronting a road should be avoided. Dormer windows will not normally be permitted in side roof slopes where the privacy and amenity of adjacent dwellings is adversely affected

Alterations to attics will need to be checked for headroom and access via new staircases.

## PORCHES

Adding a porch or a canopy is one of the most significant changes a householder can make to the front of a house as it involves a change to the entrance which is the focal point.

Additions should enhance rather than detract from the original house. (Seek to retain original porch designs whenever possible). A plain rectangular box with a flat roof is generally unsympathetic to the existing building.

Where front doors are paired, work closely with your neighbour to get a matching design and reduced costs. Porches generally look better if the door is either placed centrally and set well back in a reveal or if the porch is open.

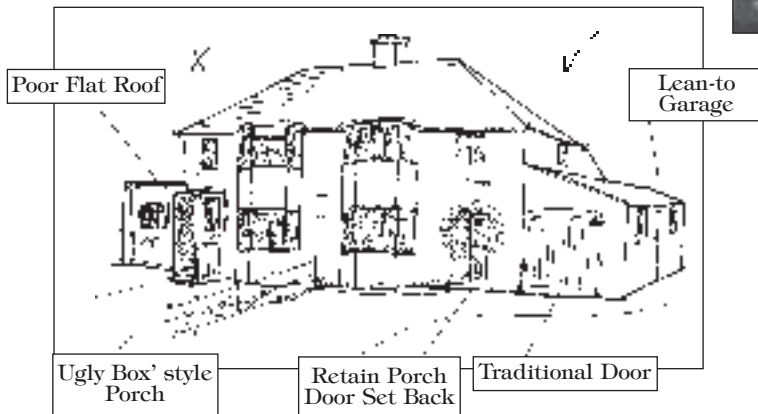

# EXTENSIONS FOR RELATIVES OR DEPENDANTS

It is important that extensions for relatives or dependants are designed to be integral, ancillary and subordinate to the existing house. They should take the form of an extension to the dwelling with internal links to the main accommodation.

The formation of a “granny annexe” in a detached outbuilding will not normally be acceptable as this is effectively the creation of a new dwelling.

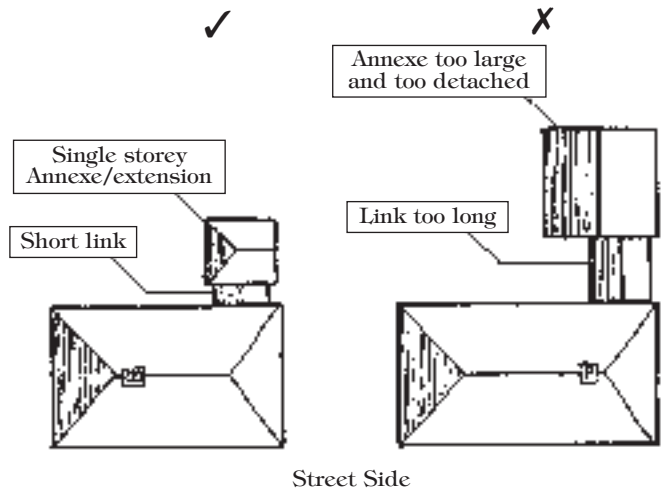

# CONSERVATORIES

Conservatories should be constructed in materials which are in-keeping with the existing building. Attention must be given to the position and size of a conservatory to avoid unreasonable overlooking of neighbouring gardens or prominence in the street scene. The roof pitch should mirror that on the main house.

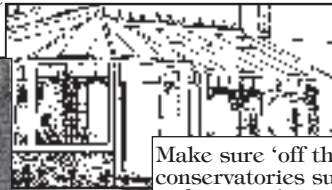

Make sure 'off the peg' conservatories suit your building - unfortunately many have too shallow a pitch and are a mix of mock Victorian/Georgian and gothic

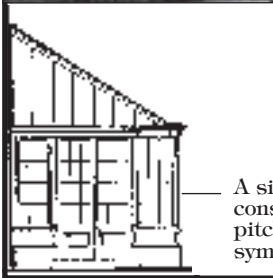

A simple 'lean-to' conservatory with a steep pitch is often the most sympathetic and attractive



Form/Pitch too Shallow



Match the proportion and pitch of existing roofs



# WINDOWS AND DOORS

It is important that the extension continues the existing pattern and type of openings in walls. The size, proportion, height, style and ratio of solid wall to opening all create the character of your house. Traditionally walls dominate over windows simply because small windows were only possible due to the use of wood or stone lintels and the slow emergence of glass technology.





Match details

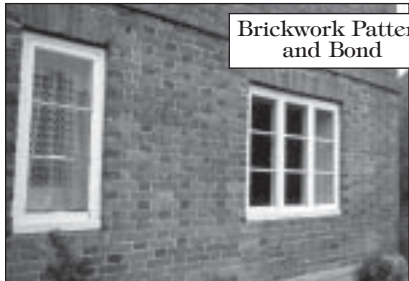

Brickwork Pattern and Bond



Proportion and Balance



Verges and Projections



Brickwork Dressings

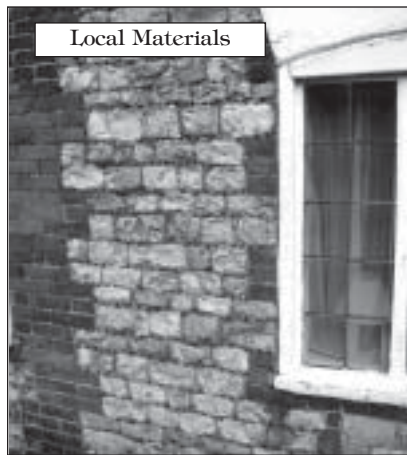

Local Materials



Eaves



Eaves

## MATERIALS

New materials should match those of the existing house. Special care should be given to the selection of the type, colour and size of bricks, roof tiles, mortar colour, lintels, cills and heads.

In some areas it will be particularly important that traditional local materials such as are used, such as Selborne malmstone, ironstone, flint, slate etc.

## DETAILS

It is important that an extension incorporates details to match those of the main dwelling. In particular heads and cills, brick coursing and quoin work, ridge, verge and eaves finishes.



# ADDITIONAL POINTS TO CONSIDER

## Overlooking

The design of any extension must ensure that the privacy enjoyed by neighbouring properties is not significantly reduced by overlooking.

Side windows in extensions should not be placed where they may cause overlooking and unreasonable loss of privacy to an adjoining property. High level windows with a minimum cill height of 1.67 metres from finished floor level may be acceptable in side windows where there is no alternative solution. Opaque glass may need to be used in certain circumstances.

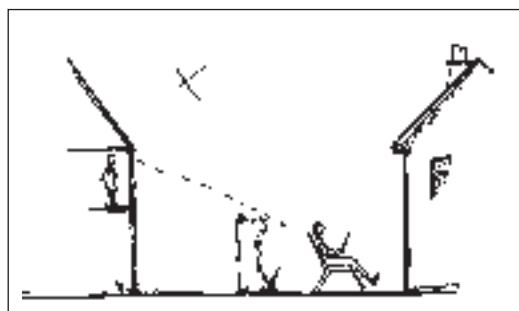

## Orientation

New extensions will cast new shadows. In exceptional cases planning applications may be refused on the grounds of overshadowing. It is important to consider where shadows are going to fall and the effect this will have on adjacent properties. Any extension should seek to minimise overshadowing.

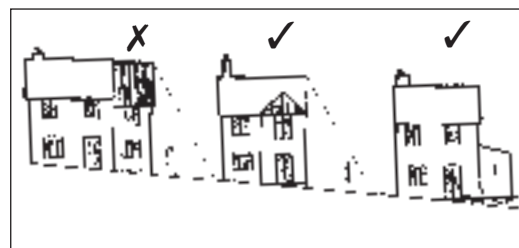

## Garden Space

A reasonable size and shape of garden is as important as the size and shape of rooms in the house. An extension should not result in a major loss of garden area and thus result in an overdevelopment of the plot.

## Trees and Hedges

Trees and hedges are important features in the character of the area and every effort must be taken to ensure that trees and hedges are retained. Always check first that the trees are not protected by a Tree Preservation Order or are situated in a Conservation Area : if they are the specific permission is required before the trees can be removed or have work done to them.

All building work should be carefully considered in relation to the branches and roots of trees and their possible future growth.

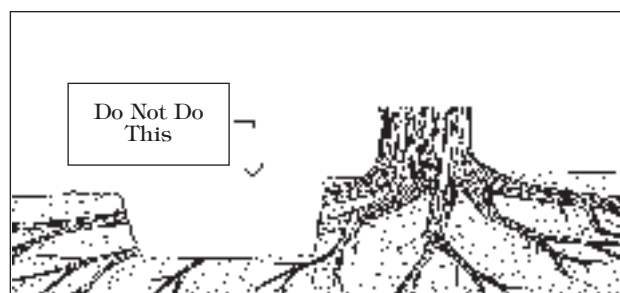

Proposals for development which require new service provision, e.g. cables, sewers or drains must also take into account the position of tree roots.

*Specific advice on this is available from the Council's Landscape Officers and in BS5837:1991 - Guide for Trees in Relation to Construction.*

## Car Parking Provision

Existing provision for car parking should be retained. In unsustainable locations, if you are increasing the number of bedrooms from 3 to 4 or more then provision for parking three cars clear of the road will normally be required within the site.

If existing parking provision will be lost through an extension or conversion it should be re-provided elsewhere on the site. Car parking across the whole of the frontage is unlikely to be acceptable. Where additional parking at the front is acceptable a minimum depth of 5 metres will be required (5.5 metres if a parking space is to be provided in front of a garage). In some instances a turning area will also be necessary.

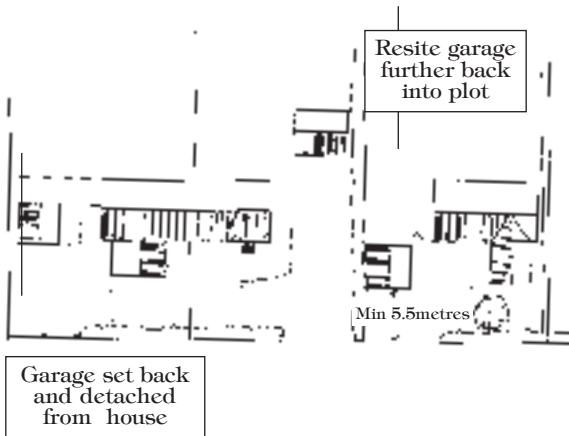

Garaging can spoil a traditional facade - be careful where it is sited

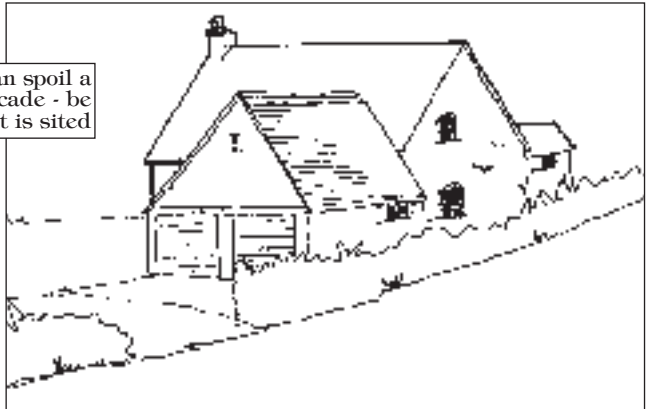



## OTHER INFORMATION

### Work not needing planning permission

Not all extensions require planning permission. A leaflet explaining what can be built without planning permission is available from the Council. **You are strongly advised to obtain written confirmation from the Council that planning permission is not required prior to the commencement of any work.**

### Building Regulations

Almost all house extensions require approval under the Building Regulations. Further information can be obtained from the Council's Building Control Section. (see below)

**Obtaining Building Regulations approval *does not* mean that you have also obtained Planning Permission, Conservation Area Consent or Listed Building Consent - you may need to apply and obtain these as well. CHECK before you start work!**

### Historic Buildings and Conservation Areas

In addition to planning permission, Listed Building Consent and/or Conservation Area Consent may be required in some instances. This can be confirmed by the Council's Conservation Officers.

Further advice on the points raised in this leaflet is available from the District Council's Planning Control Section. Officers will be pleased to discuss your particular situation and proposals in more detail.

Further information on Listed buildings and Conservation Areas is available from the District Council's offices at Penns Place, Petersfield GU31 4EX.

For specific advice please contact:

<b>Planning Control Section</b>	<b>01730 234246/4248</b>
<b>Heritage Section</b>	<b>01730 234214</b>
<b>Landscape/Trees Section</b>	<b>01730 234214</b>
<b>Building Control Section</b>	<b>01730 234207/4208</b>
<b>Highways</b>	<b>01730 234298</b>

## BIBLIOGRAPHY, REFERENCES, FURTHER READING

- The Conservation Directory - East Hampshire DC 1994 +  
Development Control Design Guide 2 - 1994  
- Basingstoke & Deane BC
- Domestic Extensions - Hart DC 1994
- New Houses in Towns & Villages - Aylesbury Vale DC 1993.
- Vernacular Architecture - R . W . Brunskill 1978
- Traditional Building in Britain - RW. Brunskill 1989
- Listed Building Consent  
Conservation Area Consent  
“Help us to Help you”. - EHDC 1994/1995
- Listed Buildings in East Hampshire  
- A Guide to the Law. - EHDC 1993
- Planning Policy Guidance Note-1  
- General Policy and Principles - Department of the Environment  
1992 - (1997 Rev)
- Planning Policy Guidance Note 15  
- Planning & the Historic Environment - Departments of Environment and  
Department National Heritage.1994
- “Quality in Town and Country” - Department of Environment  
Paper 1994.
- “Local Attraction” - The Design of new  
Housing in the Countryside. - C.P.R.E. 1995
- Planning. A Guide for Householders - D.T.L.R. March 2002
- Local Village Design Statements - Check with EHDC  
Planning Services - see opposite

\* This document text ‘Extending your Home’ has the approval of the Development Policy Committee East Hampshire District Council and Area Committees North and South 1995 and was subject to the consultation of Town and Parish Councils of East Hampshire 1994/95

**EAST HAMPSHIRE**

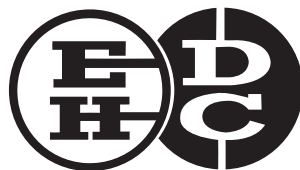

***Partners***

**[www.easthants.gov.uk](http://www.easthants.gov.uk)**